

一 安全上的注意事項

- 1-1 作業環境的安全
- 1-2 安裝的安全
- 1-3 操作中的安全
- 1-4 保養維修的安全
- 1-5 危險標示,請注意標示

二 使用說明

- A 安裝
- B 潤滑
- C 潤滑油之更換
- D 濾油器之更換
- E 針之更換
- F 穿線方式
- G 押腳壓力強度之調整

三 調整說明

- A 針棒高度之調整
- B 針與勾針之時位關係
- C 下勾針與針之引量
- D 勾針與針之間隙關係
- E 針與後護針片調整
- F 針與前護針片調整
- G 針與上勾針及線導片之關係
- H 送步齒高度調整
- I 勾針控線凸輪之調整

四 自動切線調整說明

- A 下切刀組相關位置調整
- B 下切刀組切線之相關位置
- C 下切刀組與針線及下勾針線之關係
- D 上切刀組與上飾線,針及上勾針之關係
- E 撥線器相關位置調整

五 簡易故障排除

- A 清潔保養
- B 故障(用戶)自主檢查
- C 結論

SAFETY PRECAUTION

- 1-1 WORK ENVIRONMENT 1
- 1-2 SAFETY IN INSTALLATION 2
- 1-3 SAFETY IN OPERATING 3
- 1-4 SAFETY IN MAINTENANCE AND REPAIRS 3
- 1-5 DANGER AND CAUTION SIGNS 4

OPERATION GUIDE

- A INSTALLATION 5
- B LUBRICATION OIL 6
- C OIL CHANGE 7
- D REPLACING OIL FILTER 7
- E HOW TO REPLACE THE NEEDLES 8
- F THREADING 8
- G ADJUSTING THE PRESSURE OF PRESSER FOOT 9

ADJUSTMENT GUIDE

- A THE HEIGHT OF NEEDLE BAR 10
- B TIMING OF NEEDLE AND LOOPER 11
- C THE POSITION OF NEEDLE AND LOOPER 12
- D THE TIMING OF NEEDLE AND LOOPER 13
- E ADJUSTING NEEDLE AND REAR NEEDLE GUARD 14
- F ADJUSTING NEEDLE AND FRONT NEEDLE GUARD 15
- G "THE RELATIVE POSITION OF NEEDLE, SPREADER" AND SPREADER THREAD GUIDE 16
- H ADJUSTING THE HEIGHT OF FEED DOG 17
- I THE ADJUSTMENT OF LOOPER THREAD TAKE-UP 17

AUTO THREAD TRIMMER ADJUSTMENT GUIDE

- A THE RELATIVE POSITION ADJUSTMENT OF BOTTOM TRIMMER CUTTING PARTS TRIMMER CUTTING PARTS 18
- B THE RELATIVE POSITION ADJUSTMENT OF BOTTOM TRIMMER. 20
- C "THE RELATIVE POSITION OF NEEDLE, LOOPER" THREAD AND BOTTOM TRIMMER. 22
- D "THE RELATIVE POSITION OF SPREADER THREAD," "NEEDLE, SPREADER AND TOP TRIMMER." 23
- E THE RELATIVE POSITION OF TOP WIPER 25

REGULAR MAINTENANCE

- A THE CLEAR AND MAINTENANCE 26
- B ERROR MESSAGES(THE USER INSPECTS THE MACHINE BY THEMSELVES) 28
- C CONCLUSION 32



SHING RAY®

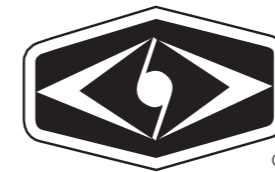

SHING RAY®

安全上的注意事項：

使用本機前請詳細閱讀本說明書及所搭配之馬達說明書，配合正確使用，並須由受過正確訓練之人員來安裝或操作。

1-1 作業環境的安全

(1) 電源電壓：

電源電壓請遵照馬達與控制箱牌所標示之規格±10%範圍內操作。

(2) 電磁波干擾：

請遠離高週磁波器或電波發射器等，以免產生的電磁波干擾本驅裝置，因而發生錯誤作。

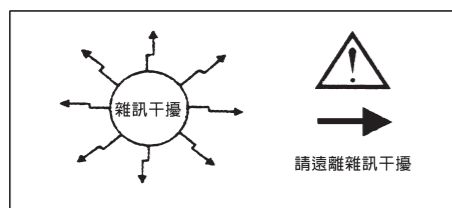

(3) 溫濕度

1. 請不要在室溫45度C以上或5度C以下的場所操作。
2. 請不要在日光直接照射的場所或室外運作。
3. 請不要在暖氣(電熱器)旁運作。

SAFETY PRECAUTION :

Please read this manual carefully, also with related manual for the machine head before use. For perfect operation and safety, installing and operating this product by trained personal is required. When install and operate HVP-70 MINI SERVO MOTOR, precaution must be taken as the following. This product is designed for specify sewing machine and must not be used for other purposes.

1.1 Work Environment :

(1) Power voltage :

Only use Power Voltage indicated on the name plate of the HVP-70 + 10% ranges.

(2) Electromagnetic pulse interference :

To avoid the false operate, please keep the product away from the high electromagnetic machinery or electro generator.

(3) Temperature :

- a. Please don't operate in room temperature is above 45 C or under 5 C
- b. Avoid operating in direct sun light or outdoors area.
- c. Avoid operating near the heater.

4. 請不要在相對濕度30%以下或95%以上或有露水的場所運作。

1-2 安裝的安全

(1) 機器、馬達、控制箱：請遵照說明書正確裝好。

(2) 電源線：

1. 請注意不要被外物壓住或過度扭曲電源線
2. 裝釘電源線時請不要靠近會轉的手輪、皮帶輪及三角皮帶，最少要離開3~5公分以上。

(3) 接地：

1. 為防止雜訊干擾或漏電事故，請做好接地工程。
2. 電源線的接地線須以適當大小的導線和接頭連接到生產工廠的系統地線，此連接必須被永久固定。

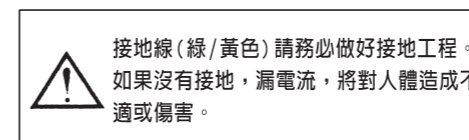
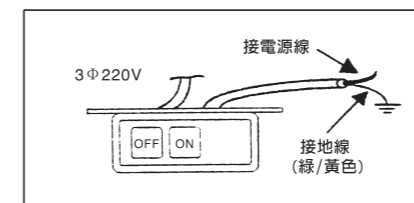

- d. Avoid operating in the area which humidity is 30% or less and 95% or more, also stay away from dew area.

(4) Atmosphere :

- a. Avoid operating in dusty area, and stay away from corrosive material.
- b. Avoid operating in evaporate or combustible gas area.

1.2 Safety In Installation :

(1) Motor and control box :

Follow the instruction in this manual for correct installation.

(2) Power cord :

- a. Avoid power cord being applied by heavy objects of excessive force, or over bend.
- b. Power cord must not set to be near the handwheel, keep 3mm spare or above.
- c. Check the outlets voltage before plugging the cord, make sure it match the voltage shown on the name plate of the HVP-70 in + 10% ranges.

(3) Grounding :

- a. To avoid the static interference and current leakage, all grounding must done.
- b. Use the correct connector and extension wire when connecting ground wire to Earth and secure it tightly.



SHING RAY®

1-3 操作中的安全

- (1) 在第一次開電後，請先以低速操作縫紉機，並檢查轉 方向是否正確。
- (2) 縫紉機運轉時請不要去觸摸手輪、皮帶輪、三角皮帶、天秤、針等會作的部位。
- (3) 請不要在拆下皮帶護蓋及其它安全裝置的情形下操作。
- (4) 操作縫紉機時，針棒前方之透明護目板，必須移到針鉤前方之正常位子。

1-4 保養維修的安全

在操作以下 作前，請先關閉電源：

- (1) 要拆卸馬達或控制箱時，或在控制

箱上插或拔任何連接插頭時。

- (2) 控制箱裡面有危險高壓電，所以關閉電源後要等10分鐘以上，方可打開控制箱蓋。

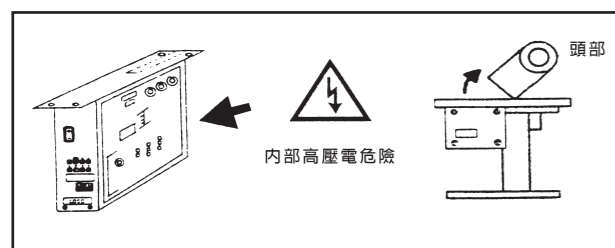

- (3) 翻抬車頭時，與更換車針或穿線時 (上圖所示)。
- (4) 機械上的修理及調整時。
- (5) 機械休息不用時。

1.3 Safety In Operating :

- (1) When turn on the machine in the first time, use low speed to operate and check the correct rotation direction.
- (2) During machine operation, don't touch any moving parts.
- (3) Please don't operate the machine under to take out the Belt Cover and another safety advice
- (4) When you operate the sewing machine, the "Eye Guide" must be moved to the correctly position which in the front of needle holder.

1.4 Safety in Maintenance and Repairs :

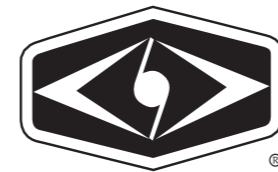

Power must be turned off first, when:

- (1) Uninstall the motor to the control box., or plug and unplug any connector.
- (2) Turn off the power and wait 10 minutes before opening box cover.
- (3) Raising the machine arms or changing needle, or threading needle.(show as above)
- (4) Repairing or doing any mechanical adjustment.
- (5) Machines rest.



SHING RAY®

1-2 危險標示，請注意標示：

- (1)  這兩個標示符號表示機器安裝時，如有錯誤會傷害到人體或機器會受到損壞，所以機器方面有危險 的地方會有此標示。
- (2)  這個標示符號表示有高壓電等電氣方面有危險 的地方會有此標示。

1.5 Danger and Caution Signs :

- (1) Risks that may cause personal injury or risk to the machine are Marked with this symbol in the instruction manual.
- (2) This symbol indicate electrical risks and warnings

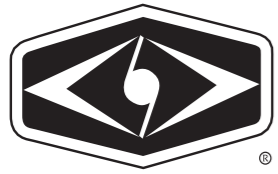

SHING RAY®

使用說明

OPERATION GUIDE

A 安裝：

1. 請依本機配件盒內電件圖所附之正確桌板尺寸裁製圖、裁製桌板。
2. 桌板厚度約 50mm。
3. 直驅微型小馬達之機頭與桌板之安裝固定方式，請參照(圖1)之安裝注意事項1、2點。
4. 直驅微型小馬達機器之桌板、腳架、電腦控制策及其他相關配件之安裝位置示意圖，請參考(圖2)。

A. INSTALLATION :

1. Before installing machine, please refer to Table Cut-Out Drawing. To cut the table out in correctly.
2. The table thickness is 50mm.
3. Please refer to (Fig. 1) and the Remark 1 & 2 for installing the "Directly Driving Type Mini-Servo Motor " machine head and table.
4. Please refer to the Installation Schematic Drawing (Fig.2) for installing the "Directly Driving Type Mini-Servo Motor" machine head, foot stand, control box and accessories.

Remark :

For security reason, We are warning all of users that please always install the grounding wire to avoid the Static Electricity.

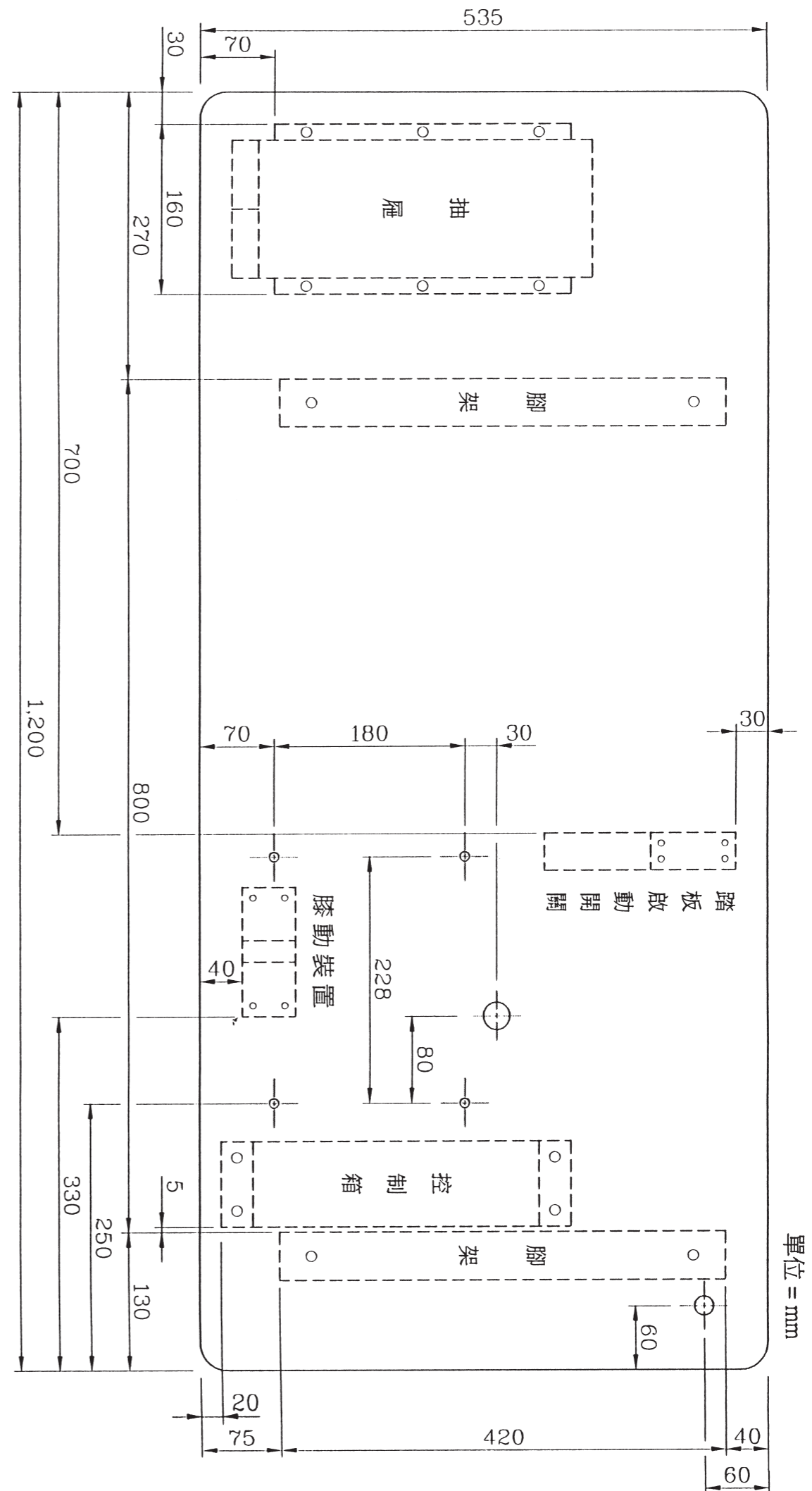

〈星銳牌 FW 787 直驅小馬達機器之桌板、車架及相關配件安裝位置示意圖〉

(圖2)

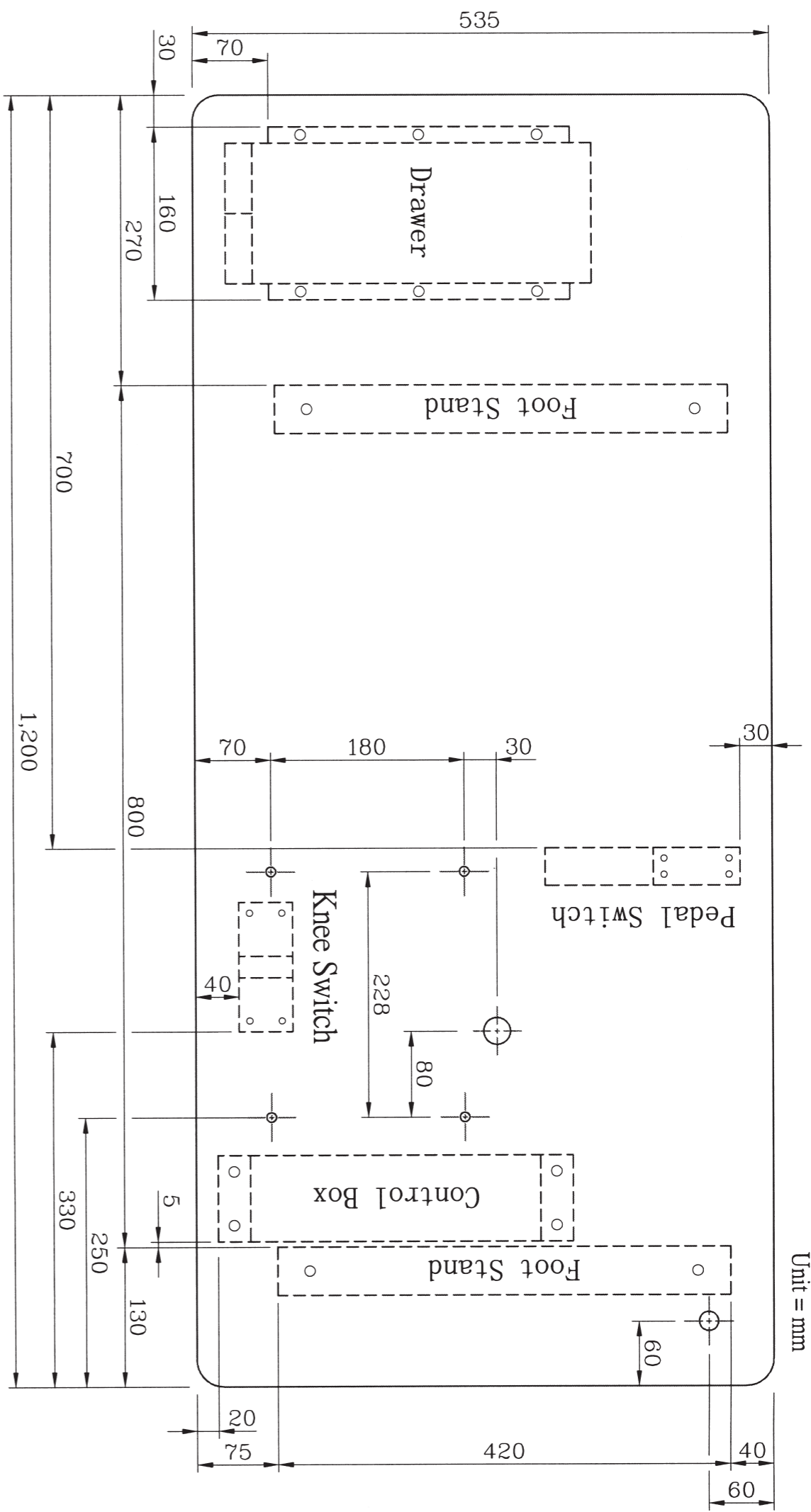

Unit = mm

微型小馬達之機頭與桌板安裝方式

(一) 桌板正面圖

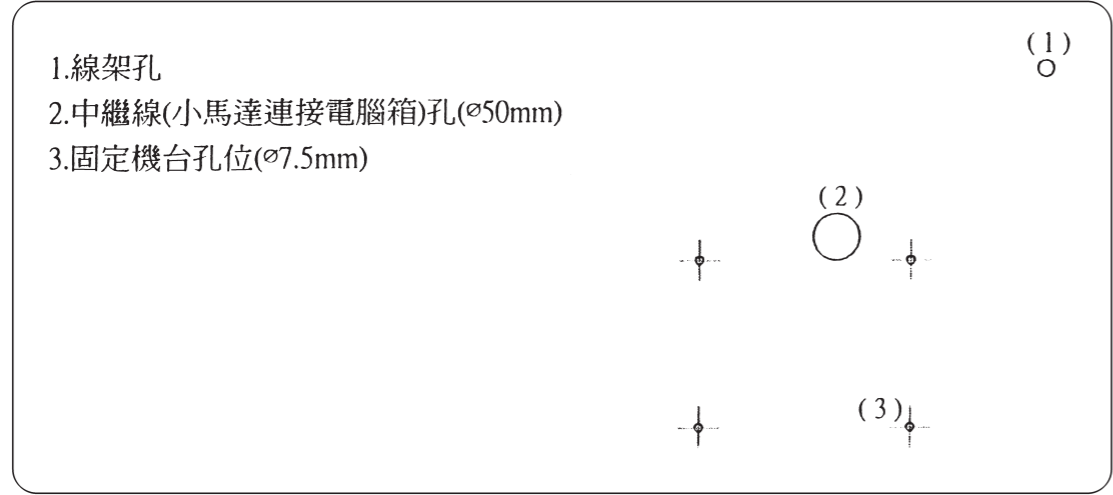

(二) 桌板分解圖

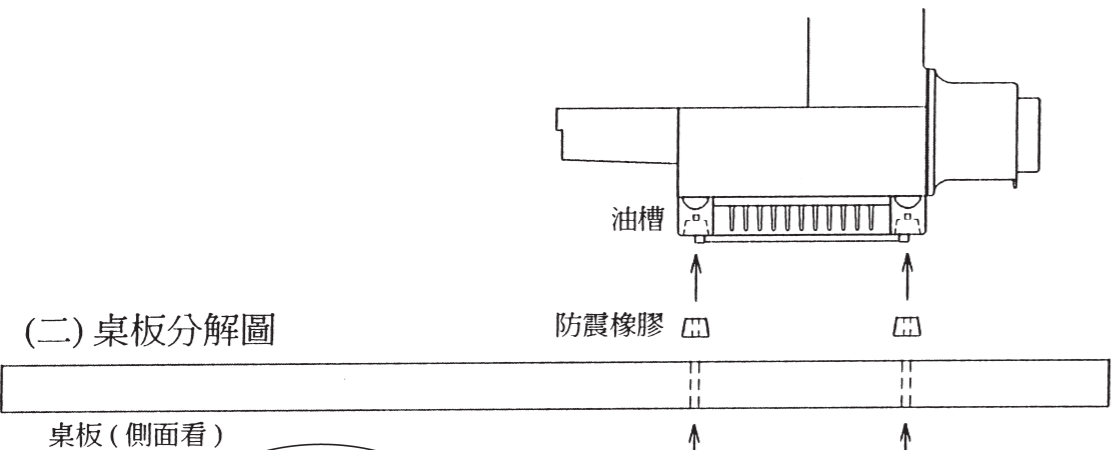

(三) 結合完成圖

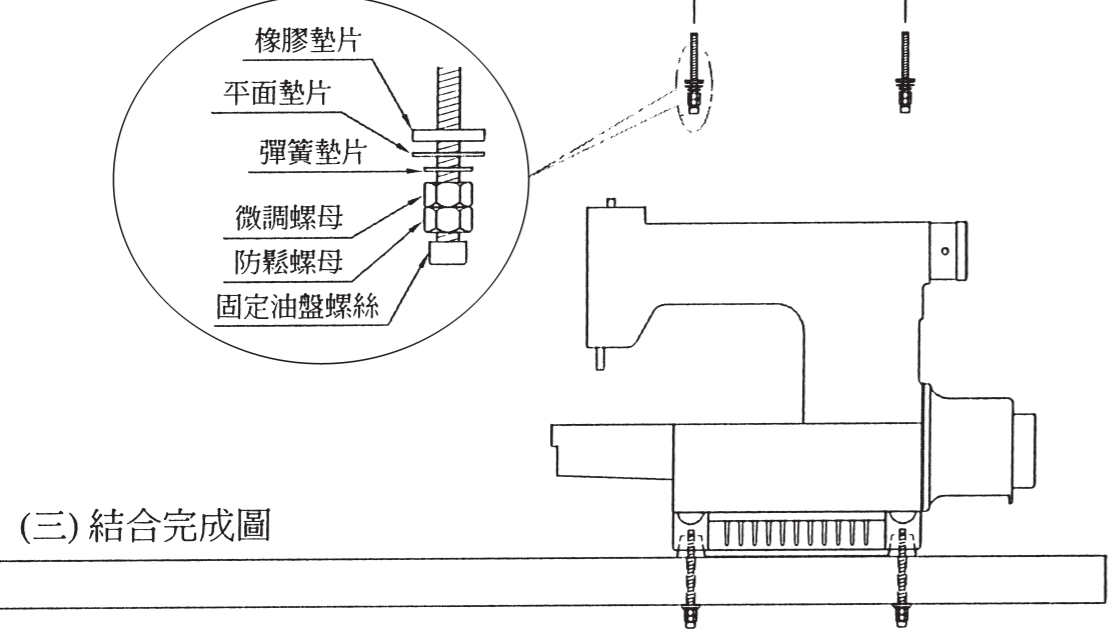

安裝注意事項: 1. 先將固定螺絲往上旋轉至頂點,再用微調螺母往上旋轉至平面墊片,接觸到橡膠墊片, (此時橡膠墊片處於被輕微夾住,平面墊片尚可旋轉狀態)防鬆螺母再鎖緊微調螺母即可.
2. 請注意4顆固定螺絲 (或微調螺母),緊度須平均以防桌板共震產生異音.

(圖1)

The Installation of Mini-Servo Motor Machine Head and Table.

(一) The Table Front View

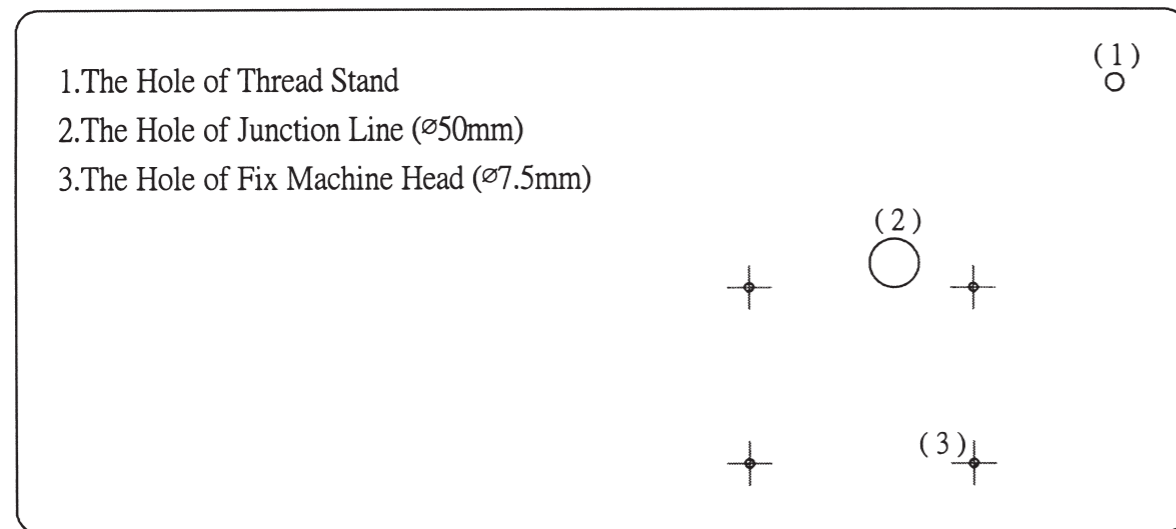

(二) The Separate Drawing of Machine Installation (Side View)

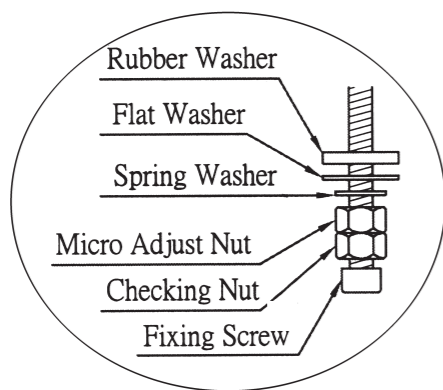
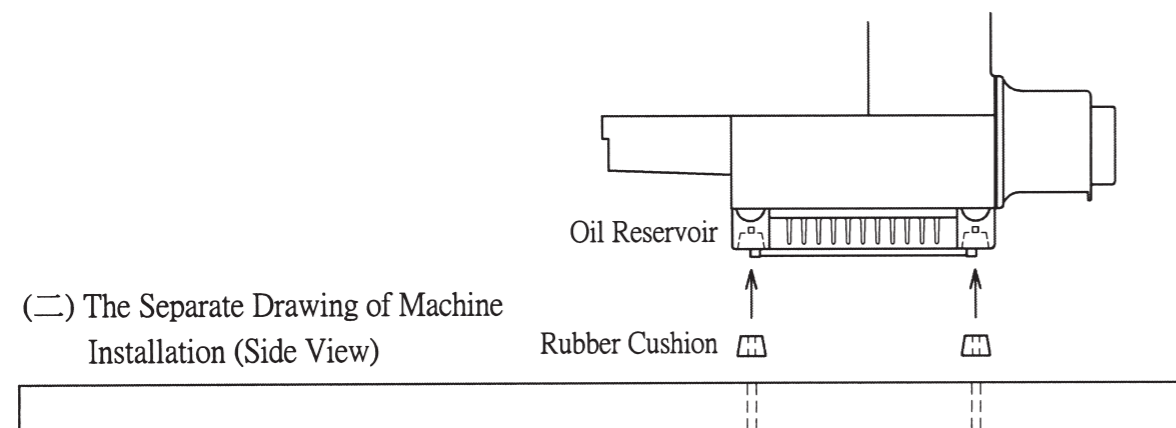

(三) The Finish Drawing

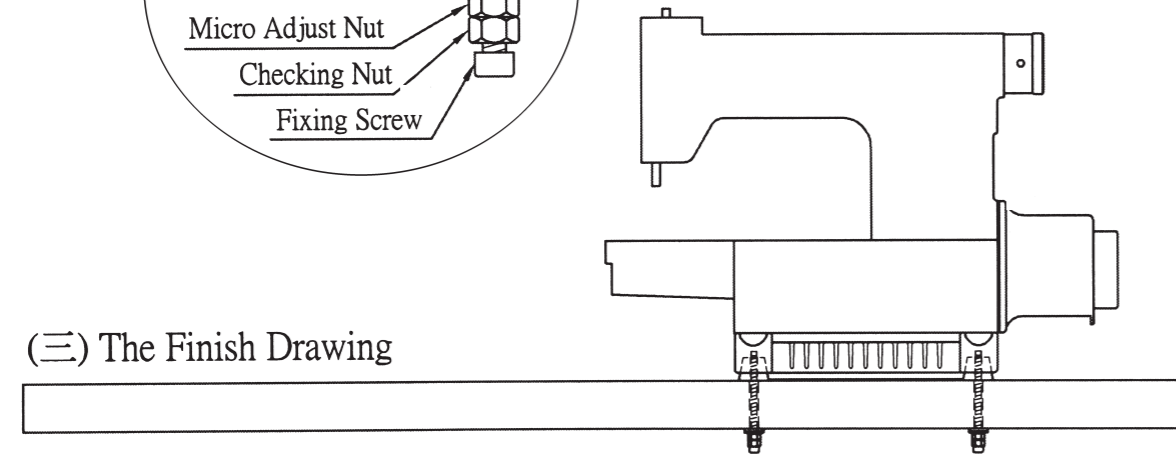

- Remark: 1. Please turn the Fixing Screw to the top. Then, the Micro Adjust Nut turn to the Flat Washer and touch the Rubber Washer. (During the time, The Rubber Washer has been clipped in lightly. The Flat Washer still could move) Finally, The Checking Nut lock to The Micro Adjust Nut.
2. The 4 Fixing Screws (or, Micro Adjust Nut) must be fixed the machine head in even which to avoid the noise of Table Resonance.

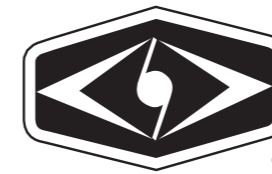

SHING RAY®

B 潤滑 :

1. 請選用與PMOBIL#10同級之潤滑油。
2. 在新機使用前請先注入潤滑油。旋開頂蓋上的噴油檢視蓋(A)，將油緩緩注入機器中，待油量滿至油標指示窗(B)上下線之間即可(圖3)。
3. 於每天開機操作時，請先檢查噴油狀態是否正常，且注意油量是否低於指示窗之下限，若低於下限請隨時補充新油。

B. LUBRICATION OIL :

1. Please use MOBIL #10 or it's equivalent.
2. Before operating the new machine, to remove Oil Sight Window (A) and fill the oil slowly until the oil level reaches between lines H and L of Oil Sight Gauge (B). (Fig.3)
3. When you begin operating the machine in everyday, please check whether all the lubricating systems at normal condition. If oil level is lower than L of Oil Sight Gauge, please refill oil.

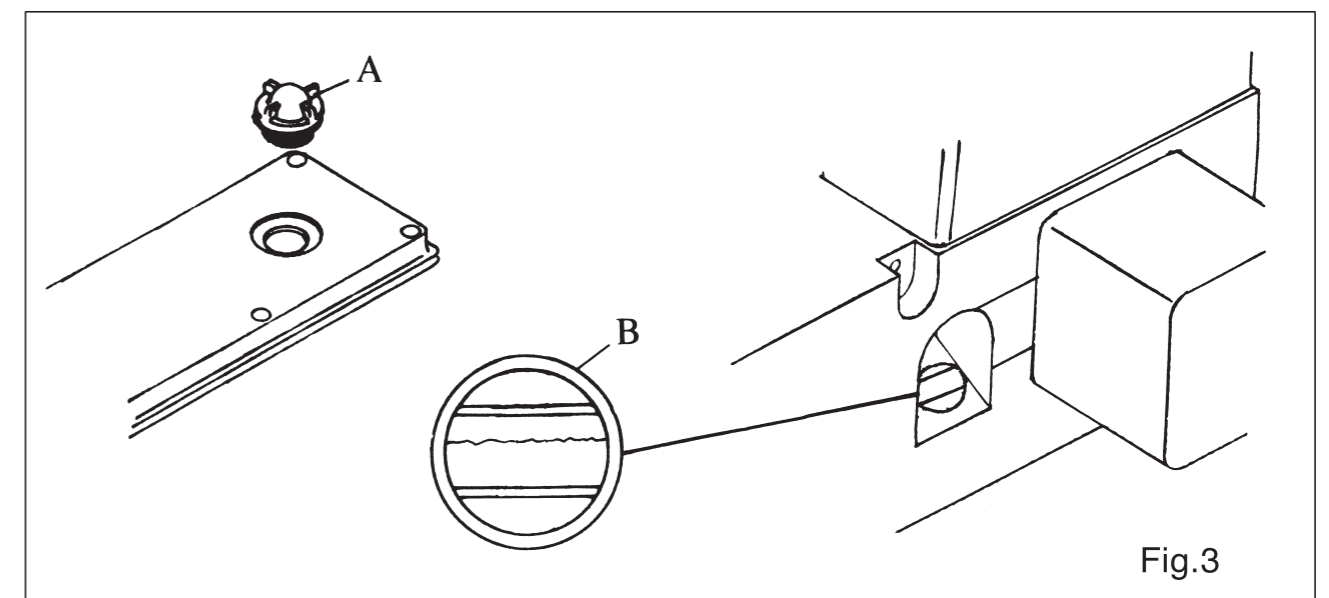



SHING RAY®

C 潤滑油之更換：

1. 將放油螺絲(A)鬆開，使油槽內的舊油完全排出後，再將放油螺絲鎖緊 (圖4)在依C-2的步驟注入新油。
2. 為延長本機的使用壽命，請於開始使用的一個月內更換第一次新油，往後約每6個月更換一次。

C. OIL CHANGE :

1. Remove screw (A) and drain all the oil from the tank. After draining, tighten screw (a) without fail. Please refer to B-2 for replenishing new oil. (Fig.4)
2. For the long life of machine, please change lubrication oil completely after one month of initial operation. After first time, to change lubrication oil every six months per time.

D 濾油器之更換：

本機裝有濾油器，新機使用一個月後必1更換新品。此後僅需每6個月更換一次。(圖5)

D. REPLACING OIL FILTER :

This machine is equipped with an Oil Filter, to change the Oil Filter after one month of initial operation. After that, please change Oil Filter every six months. (Fig.5)

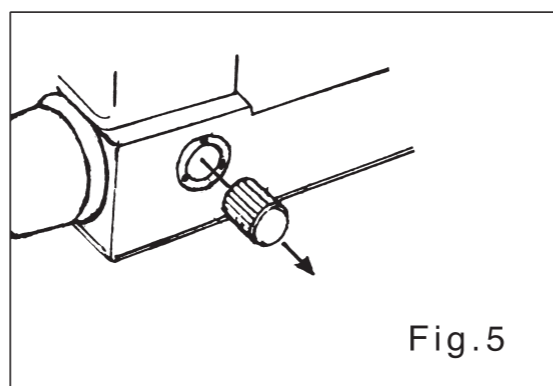
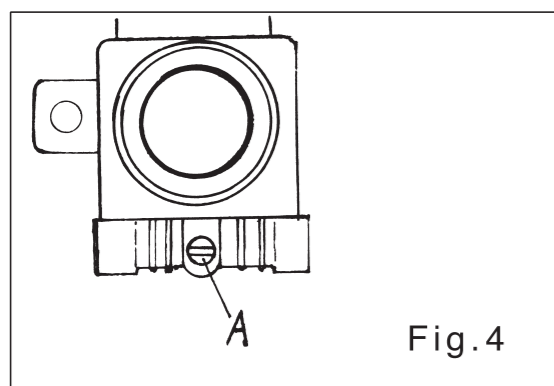

SHING RAY®

E 針之更換：

1. 請選用UY128GAS,11番的針或其他相同規格之針。
2. 旋開鎖針螺絲(A)，並取下舊針，將新針插至針座之最頂端，且使長溝面向自己。(圖6)
3. 重新將鎖針螺絲鎖緊(A)。

E. HOW TO REPLACE THE NEEDLES :

1. Please use UY128GAS #11 of Organ's needle or it's equivalent.
2. Loosen screw (A), then, pull out the used needles. Insert the new needles into the holder holes as far as they can go, and let the long groove of the needle face you. (Fig.6)
3. Fasten screw (A).

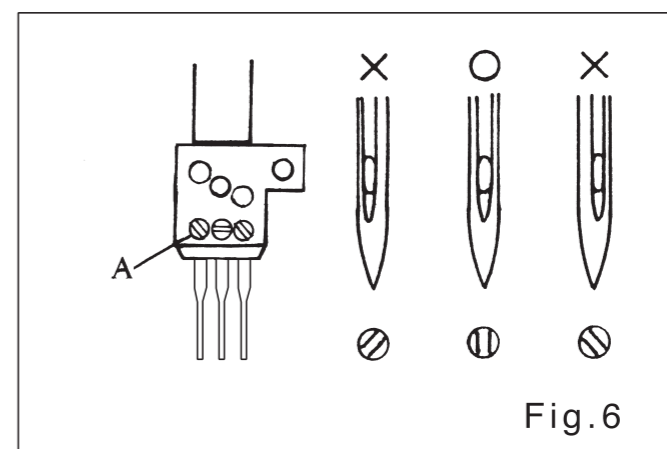

F 穿線方式：

1. 請按照圖中所指示的穿線方式正確穿線，若穿線方式錯誤，將會引起斷線、跳針或車縫不平坦等現象。(圖7)

F. THREADING :

1. Threading should be made correctly. Refer to the illustration. (Fig.7) The wrong threading may cause thread breaking, skipping stitch or puckering.



SHING RAY®

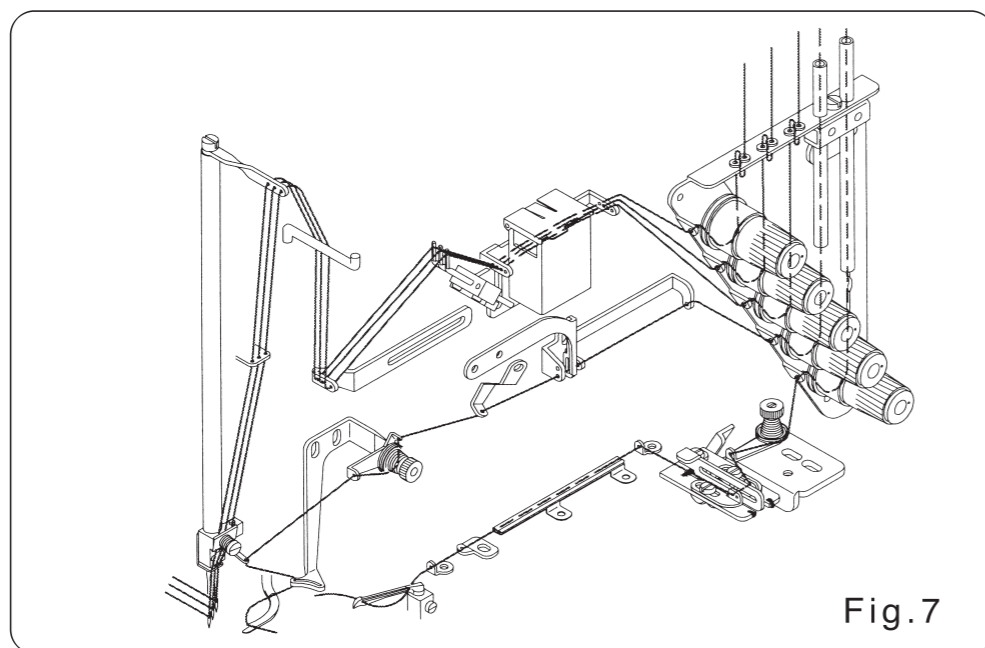

Fig.7

G 押腳壓力強度之調整：

1. 若要求布料推送順暢且縫合完美，押腳壓力應儘量輕些。
2. 鬆開螺母(A)，轉動螺絲(B)，調整其適當壓力後再鎖緊螺母(A)。(圖8)

G. ADJUSTING THE PRESSURE OF PRESSER FOOT :

1. Pressure of Presser Foot should be as weak as possible, so that cloth can be sewed and fed smoothly.
2. To increase the pressure of Presser Foot, to turn Adjusting Screw (B) clockwise after loosening Lock Nut (A) and to decrease the pressure turn Screw (B) counterclockwise. (Fig.8)

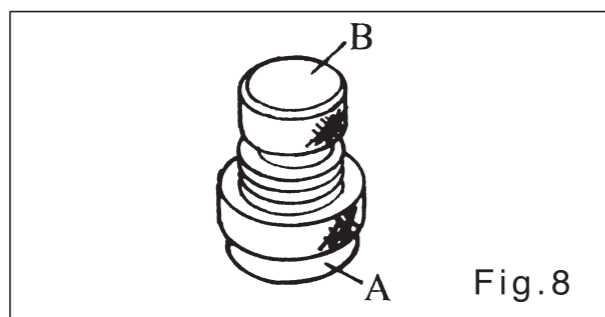

Fig.8



SHING RAY®

調整說明

ADJUSTMENT GUIDE

A 針棒高度之調整：

1. 先將針棒升到最高處，此時最長針的針尖與針板的距離為7.6~7.8mm。(圖9)
2. 若需要調整時，請先打開機頭前蓋之止油膠蓋(A)，放鬆針棒連桿上的螺絲(B)，上下調整針棒的高度後再固定之。(圖10)

A. THE HEIGHT OF NEEDLE BAR :

1. Please lift the Needle Bar to the highest position. During this time, the standard height between the longest right needle point and Needle Plate are 7.6~7.8 mm. (Fig. 9)
2. If you would like to adjust the height of Needle Bar, please remove the rubber plug of front cover and loose the screw (B) on Needle Bar Rod (A). Adjust the Needle Bar up or down to require height and fix the screw. (Fig.10)

注意：

- (1) 針必須完全裝入針錐孔最頂端。
- (2) 經過針棒高度調整後，必須確定每一根針皆通過針板的針孔正中央，不可以偏斜，且三根針需呈平行。(圖11)

Remarks :

- (1) Be sure insert the needle into the Needle Holder as far as it can go.
- (2) After the Needle Bar adjustment, please make sure that every needle are passed though the center of the needle hole on the Needle Plate. Beside, the three needles must be in parallel and the gap must be even. (Fig.11)

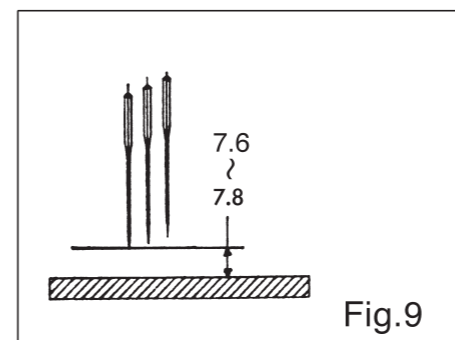

Fig.9

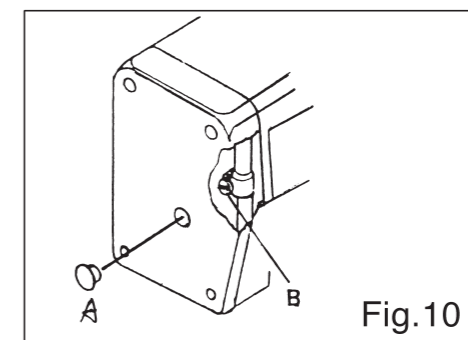

Fig.10

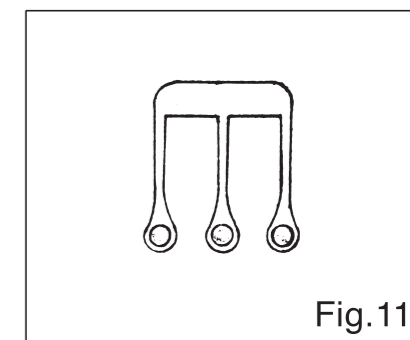
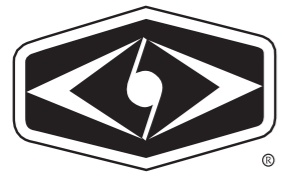

Fig.11



SHING RAY®

B 針與勾針之時位關係：

當勾針由右死點往左移至左針左側，勾針尖與針孔之距離和勾針由左死點往右回移左針右側時，勾針尖與針孔之距離(a)均相等，此為最佳之時位。(圖12、13、14)

註：

左針之針孔至勾針尖的距離約為1~1.2mm

(a)。

B. THE TIMING OF NEEDLE AND LOOPER :

When the Loper move to left from right dead point to the left side of left needle, the distance (a) between the tip of looper and needle hole is same as the Loper move to right from the left dead point to the right side of left needle. This timing is best one. (Fig. 12,13,14)

Remarks :

The clearance between the needle hole of left needle and the tip of looper is 1~1.2mm(a).

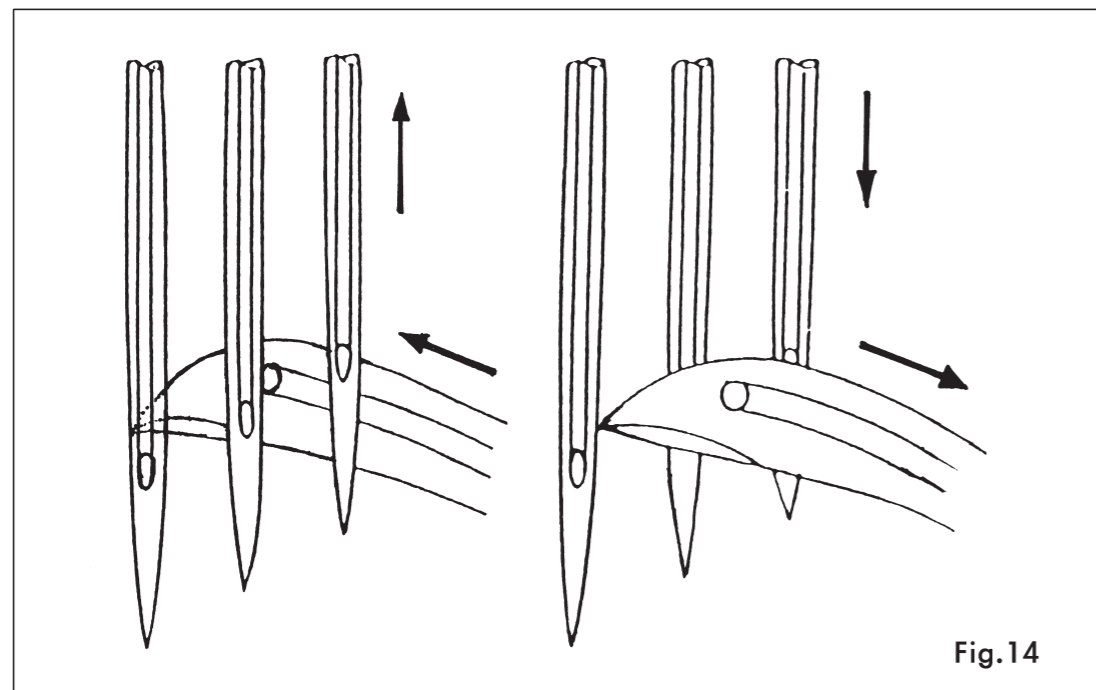
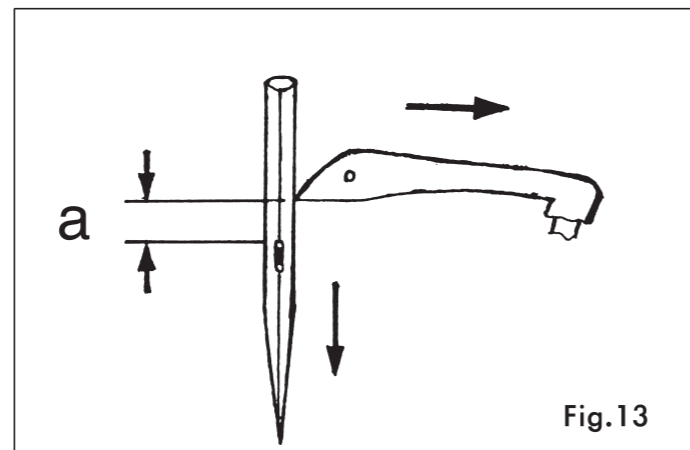
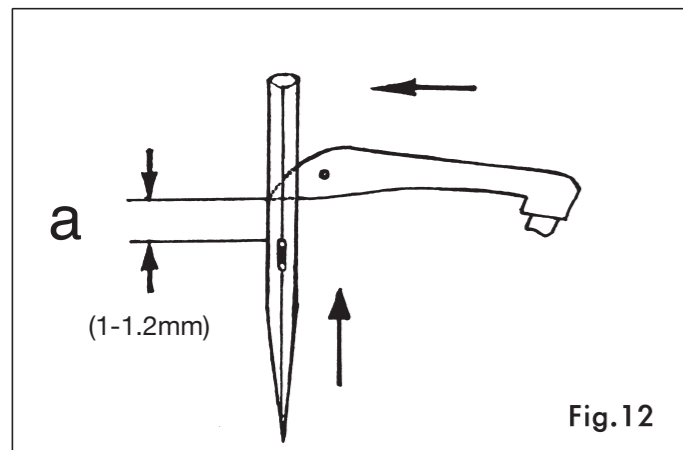

SHING RAY®

C 下勾針與針之引量：

1. 當針棒示降至最低點及下勾針退至右定點時，右針之中心點與下勾針之距離為2.8~3.0mm。

2. 鬆開勾針座上的螺絲(F)，調整下勾針與右針的正確距離(圖15)。

C. THE POSITION OF NEEDLE AND LOOPER :

1. When the Needle Bar lower to the lowest position and Loper reverse to right dead point, the distance between the center of right needle to the tip of Loper is 2.8~3.0mm.

2. Loosen the screw (F) on the Loper Holder to adjust the correctly distance of Loper and right needle. (Fig. 15)

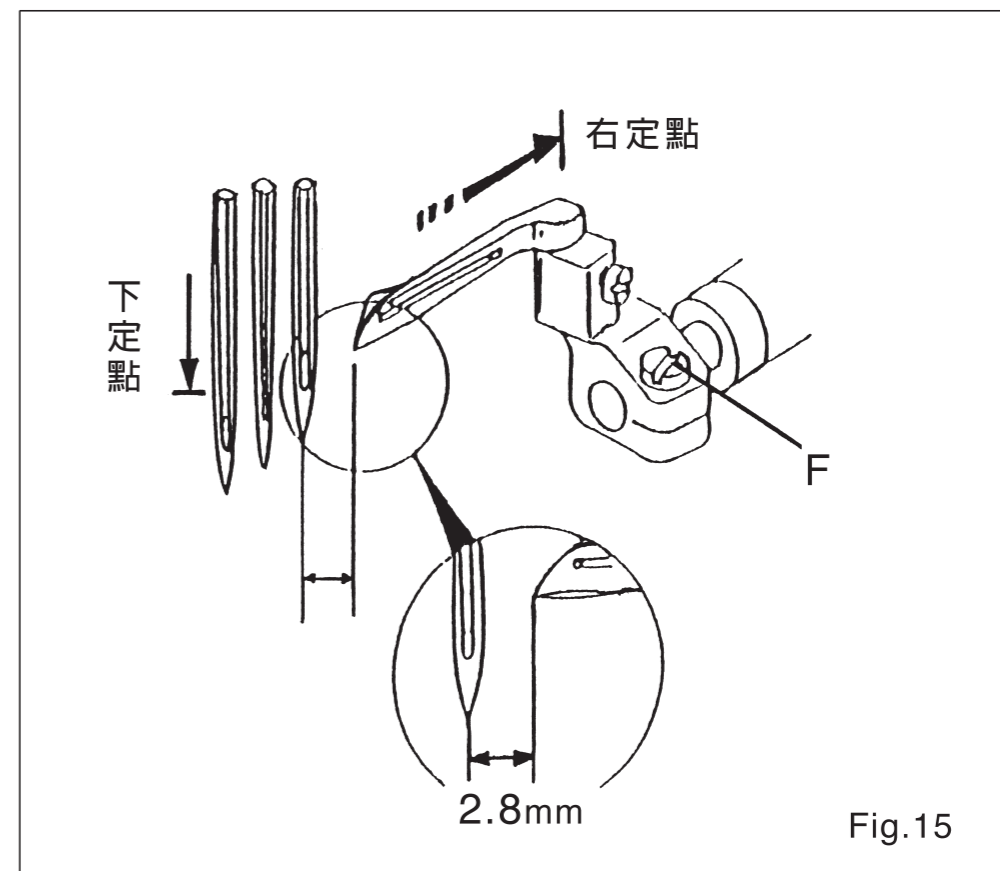

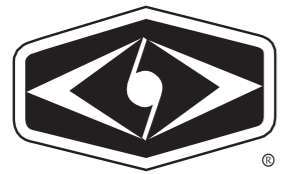

SHING RAY®

D 勾針與針之間隙關係：

勾針由右往左移至右針時，其間隙為0mm，至中針時為0.1~0.2mm，再往左移至左針時，其間隙為0.2~0.3mm。

注意：
勾針前後運之軌跡為正橢圓。

D. THE TIMING OF NEEDLE AND LOOPER :

When Looper moves to the left and meet the right needle, the clearance is 0mm. When the Looper pass the center needle, the clearance is 0.1~0.2mm. When the Looper move to left needle, the clearance is 0.2~0.3mm.

Remark :
The track of Looper pitching motion is a correct ellipse.

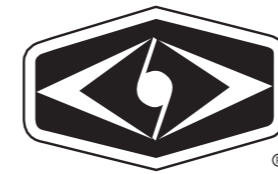
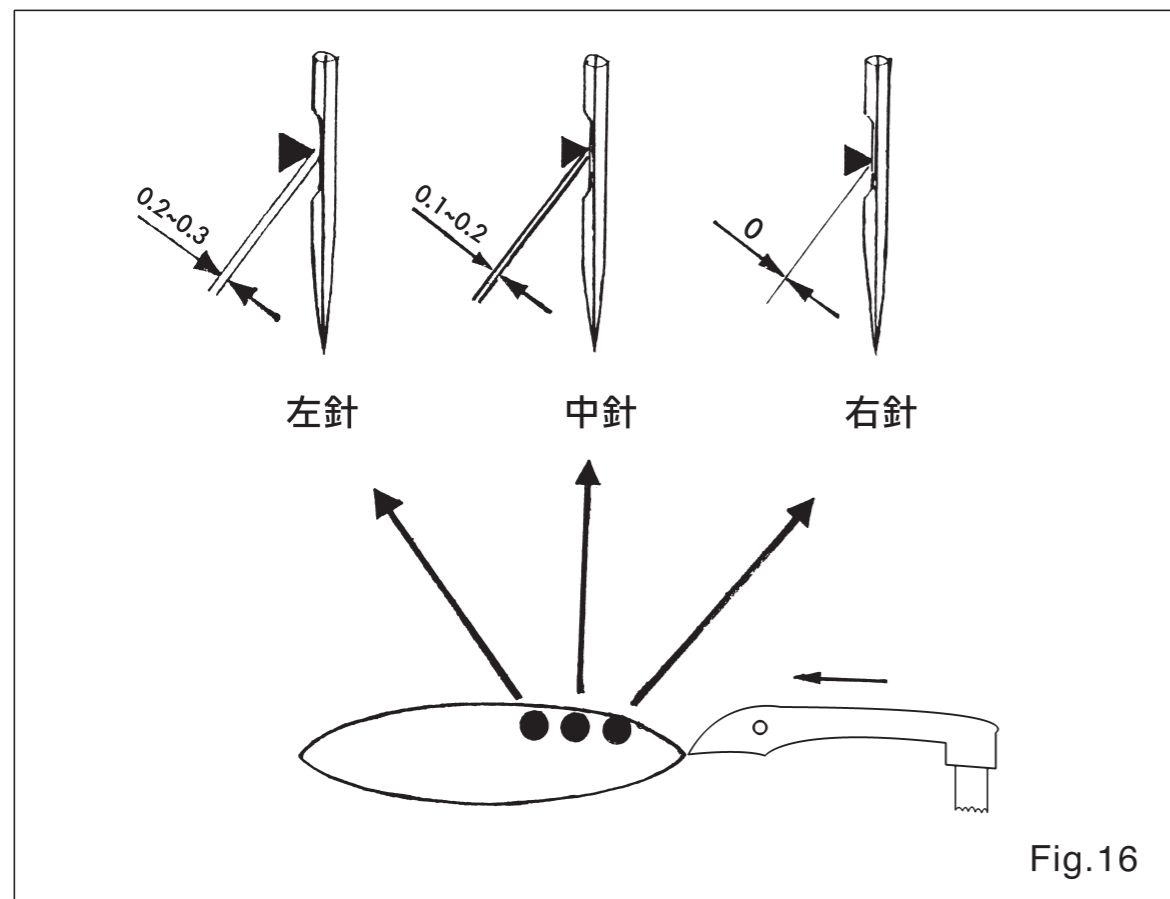

SHING RAY®

E 針與後護針片調整：

1. 當後護針片往前移出至停止不動時，後護針片之(G)線約在右針之針眼中心位置。
2. 勾針尖端前移至右針中心時，後針片往前移，與右針間隙為0.05mm，與左針間隙為0.1~0.2mm。
(圖17、18)

E. ADJUSTING NEEDLE AND REAR NEEDLE GUARD :

1. When the Needle Guard moves to the front dead point, the line (G) of Rear Needle Guard should be at the center of right needle hole.
2. When the tip of Looper moves to the center of right needle and the Rear Needle Guard to the front side, The clearance between right needle is 0.05mm and between left needle is 0.1~0.2mm (Fig.17, 18)

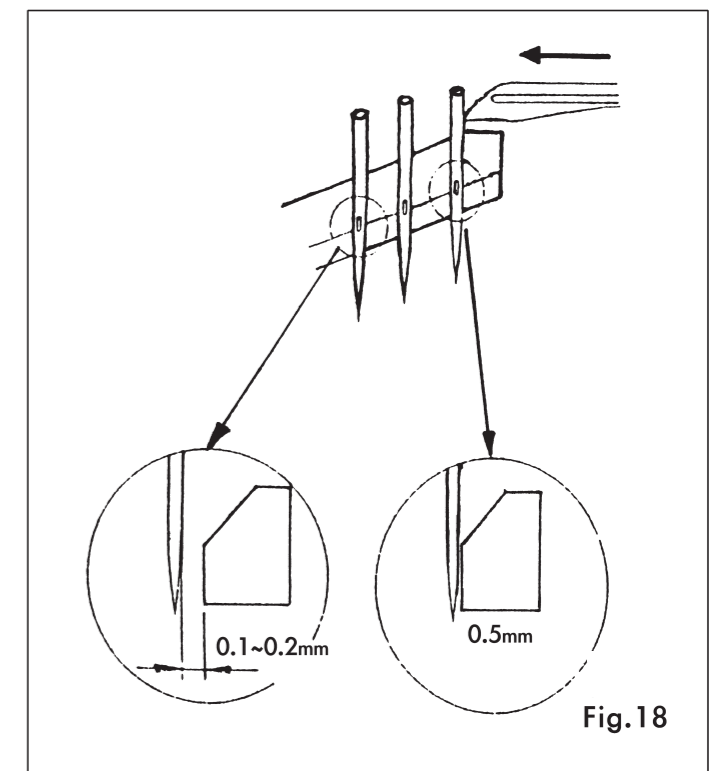
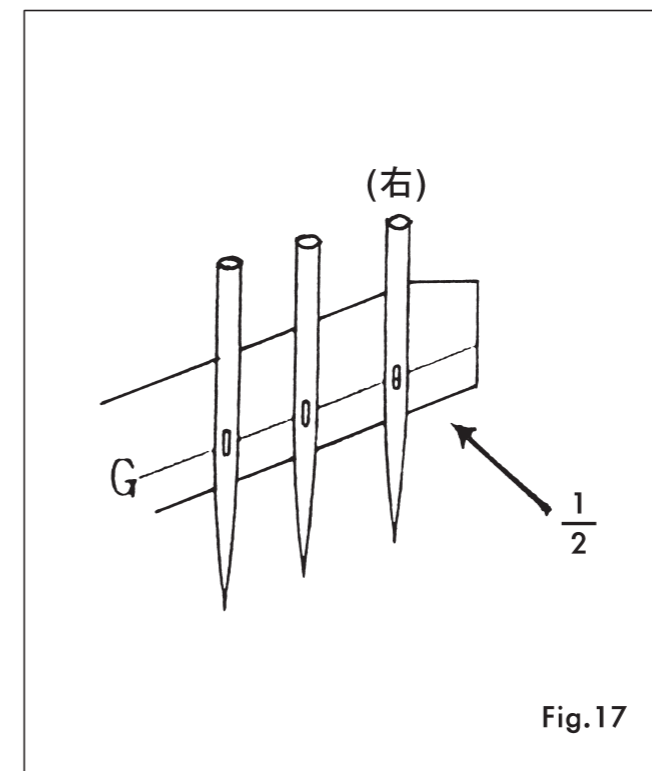

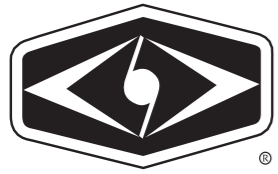

F 針與前護針片調整：

1. 勾針之尖端移到左針中心線時，左針尖與前護針片之(G)線約1.5mm，此為前護針片之高度。且左針與前護針片間隙約為0.3mm。(圖19)
2. 當勾針退到右針中心的位置時，右針與前護針片之距離亦為0.3mm。(圖20)
3. 前護針片調整好時，為平行狀態。

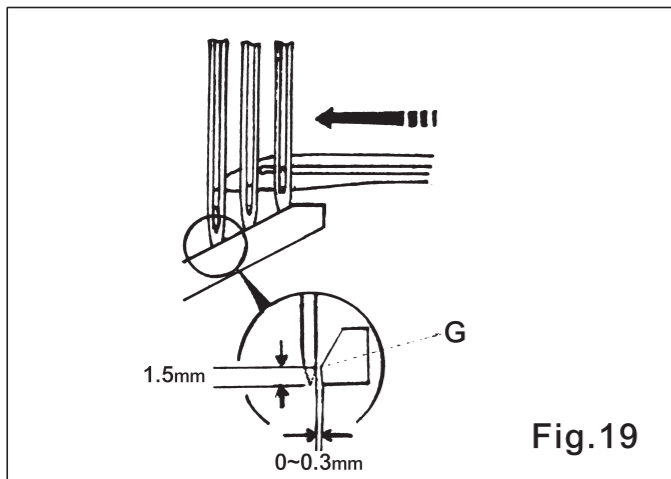

F. ADJUSTING NEEDLE AND FRONT NEEDLE GUARD :

1. When the tip of Looper moves to the center of left needle, the distance of the tip of left needle pass the line (G) of Front Needle Guard is about 1.5mm. This is the height of Front Needle Guard. The clearance between the Front Needle Guard and right needle is about 0.3mm. (Fig.19)
2. When the Looper reverse to center of right needle, the clearance between right needle and Front Needle Guard is 0.3mm. (Fig. 20)
3. When the situation of Front Needle Guard set in parallel up which meaning position is correctly.

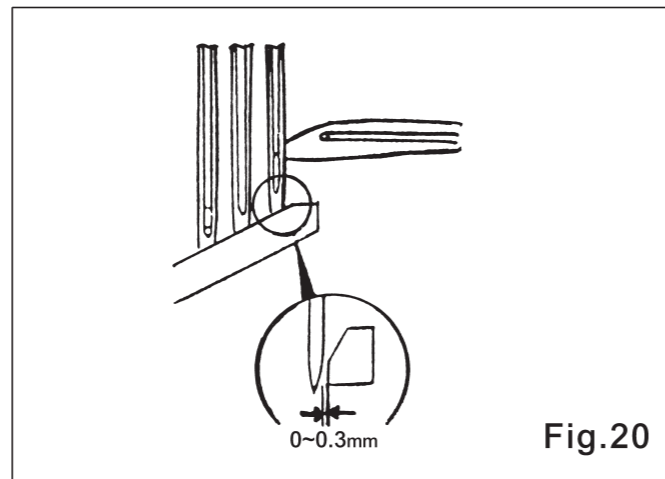

G 針與上勾針及導線片之關係：

1. 當針棒於上定位時，上勾針(A)之底部高於左針之針尖約1mm，此為上勾針之高度(圖21)。
2. 當上勾針由右往左邊移時，上勾針之勾線尖端(a)與左針之間隙為0.3~0.5mm，當上勾針繼續移至最左時，上勾針之(a)點與左針中心距離為4.5~5.5mm。(圖22)
3. 當針棒移至最低點時，上叉導板(2)之線溝剛好在導片(3)孔之下方。且上叉導板(2)與上叉(1)之間隙為0.5mm。導線片(3)與上導板(2)之間隙為1.0mm，且線孔與線溝必須相對。(圖23)

G. THE RELATIVE POSITION OF NEEDLE, SPREADER AND SPREADER THREAD GUIDE :

1. When the tip of Looper moves to the center of left needle, the distance of the tip of left needle pass the line (G) of Front Needle Guard is about 1.5mm. This is the height of Front Needle Guard. The clearance between the Front Needle Guard and right needle is about 0.3mm. (Fig.19)
2. When the Looper reverse to center of right needle, the clearance between right needle and Front Needle Guard is 0.3mm. (Fig. 20)
3. When the situation of Front Needle Guard set in parallel up which meaning position is correctly.

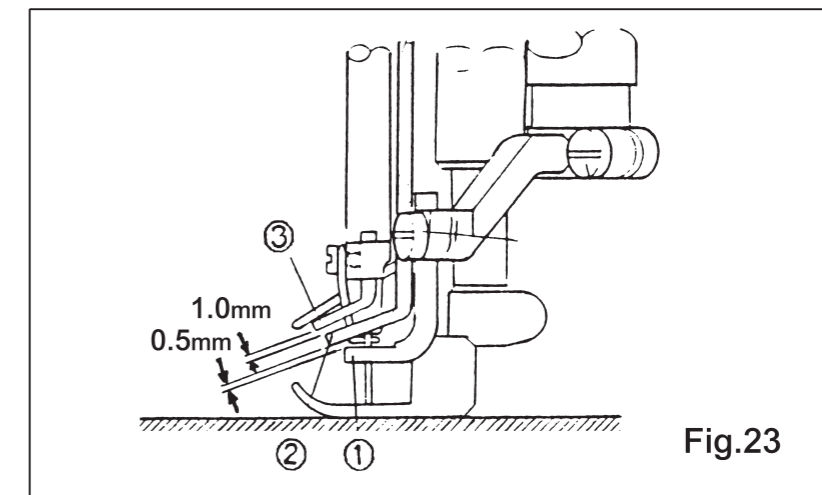
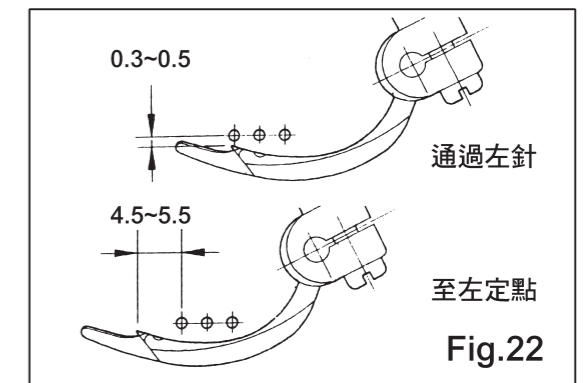
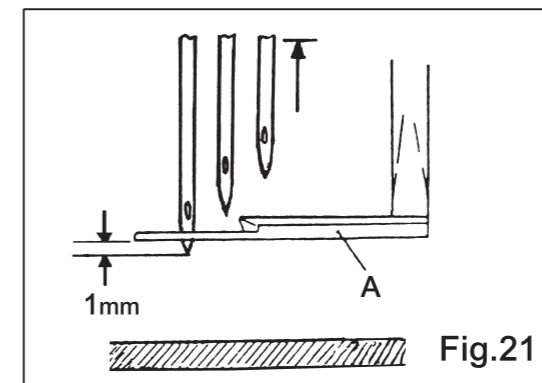



SHING RAY®

H 送布齒高度調整：

送布齒在最高位置時，送布齒齒尖面與針板面平行，且此時主送布齒(A)與差動送布齒(B)，高度相同，且齒面高出針板面1.0~1.2mm。(圖24)

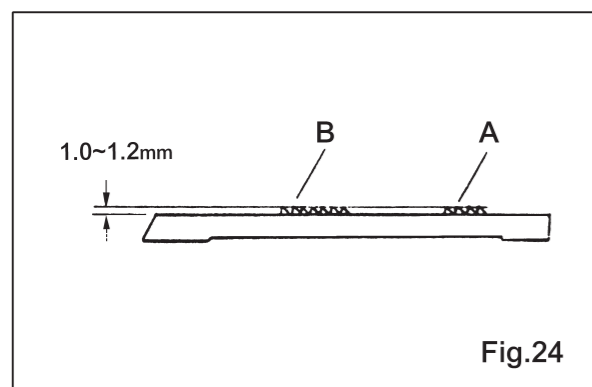

H. ADJUST THE HEIGHT OF FEED DOG :

When the Feed Dog rise up to the highest position, the surface of Feed Dog and Needle Plate must be in parallel. Besides, the teeth of Main and Differential Feed Dog must be aligned. The standard height of Feed Dog is about 1.0~1.2mm from its top teeth to Needle Plate. (Fig. 24)

I 勾針控線凸輪之調整：

1. 當針從最高點下降時，左針大約位於勾針後面之一半的位置時(圖25)，勾針線必須脫離凸輪(P)之最高位置。

2. 須調整凸輪時，放鬆22個螺絲(1)調整之。

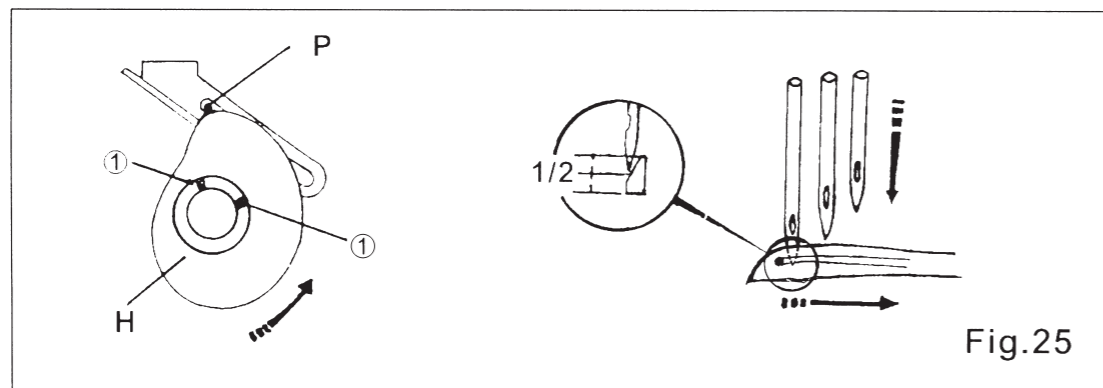

I. THE ADJUSTMENT OF LOOPER THREAD TAKE-UP :

1. When Needle comes down from the highest position, and the left Needle reaches around 1/2 position of the Loper. (Fig. 25)
The looper thread will come over the highest position of Thread Cam (P).

2. Loosen the two screws (1) for above adjustment.



SHING RAY®

自動切線調整說明

AUTO THREAD TRIMMER ADJUSTMENT GUIDE :

A 下切刀組相關位置調整：

注意：

下切刀組安裝於機器前須先檢查切刀組之相關位置和滑順度及切線效果。

1. 當活動刀片往右移時，右邊刀口之尖端(A)與固定刀之前端(B)須對齊。且活動刀移至最右點時，左邊刀口和固定刀前端的契合度為1.0mm。調整時可放鬆螺絲(C)移動固定片。(圖26)

2. 夾線片(D)之邊沿須與活動刀右邊刀口內沿切齊，如(E)。可由螺絲(C)調整。壓力片(F)前端與固定刀前端之距離約為1mm，調整時，可放鬆螺絲(G)移動壓力片(F)。(圖27)

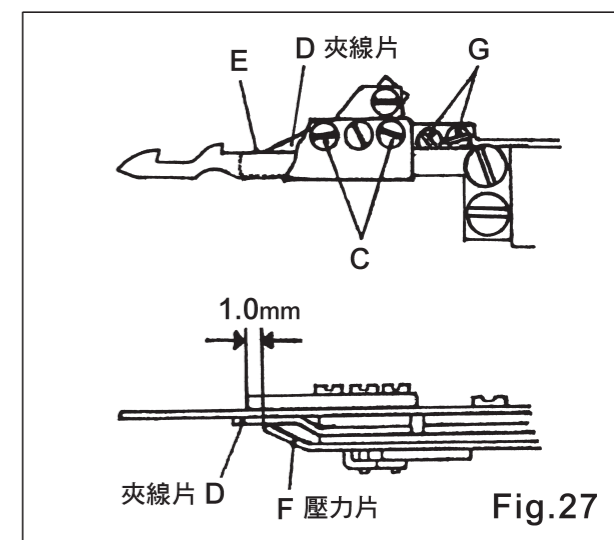
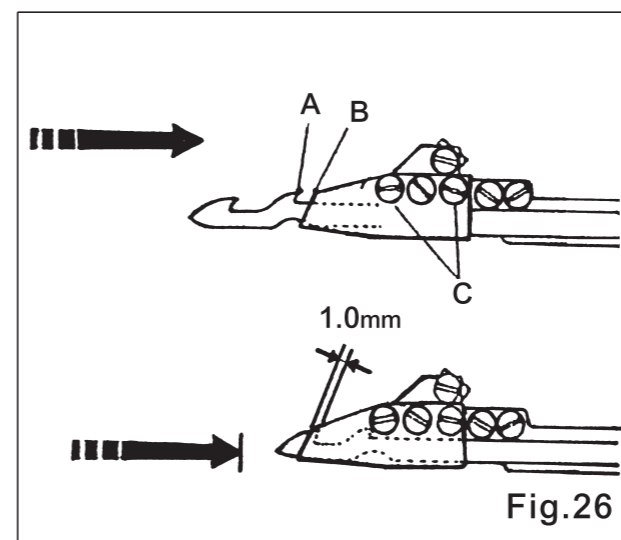

A. THE RELATIVE POSITION ADJUSTMENT OF BOTTOM TRIMMER CUTTING PARTS.

Remark :

Before you install the new Trimmer set into machine, Please always to check the relative position, the situation of sliding and the trimming effect.

1. When Lower Moving Knife move to the right, the Moving Knife hook (A) of right hand side one align with the tip (B) of Fixing Knife. When the Lower Moving Knife move to the right dead point, The Moving Knife hook of left hand side one pass the tip of Fixing Knife in 1.0mm. Loosen the screw (C) for adjusting the position of Fixing Knife. (Fig.26)

2. The edge of Clamp Spring (D) align with the inside edge of Moving Knife of right hand side hook (E). Please loosen the screw (C) to adjust the position of Clamp Spring and Fixing Knife. The distance between the top of Clamp Spring Pressure and top of Fixing Knife is about 1mm. Please loosen the screw (G) to adjust the position of Clamp Spring Pressure. (Fig.27)

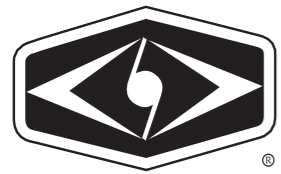

SHING RAY®

3. 夾線彈簧片的壓力調整：

當下勾針線被切斷後，下勾針這端之線頭須被夾線彈簧片與活動刀片穩定夾住。調節夾線彈簧之壓力，可由螺絲(H)旋轉調整。(順時鐘方向壓力愈強，反時鐘方向壓力變弱)。(圖28)

注意：

夾線彈簧片之壓力調整須適中，壓力太強會減短活刀片之壽命，壓力太弱則下勾針線頭易脫落。壓力之強度以能輕易切斷線即可。

3. When the looper thread has been cut off, the Clamp Spring and Moving Knife will clip the thread in stable. To increase the pressure of clipping thread turn the screw (H) clockwise and decrease the pressure turn the screw (H) counter-clockwise. (Fig. 28)

Remark :

The pressure of Clamp Spring must be moderate. If the pressure has been adjusted into too strong, it will decrease the life of Moving Knife. If the pressure has been adjusted into too weak, the looper thread will easy to lose from the Clamp Spring. What is moderate pressure? It is meaning that the pressure to cut the thread easily.

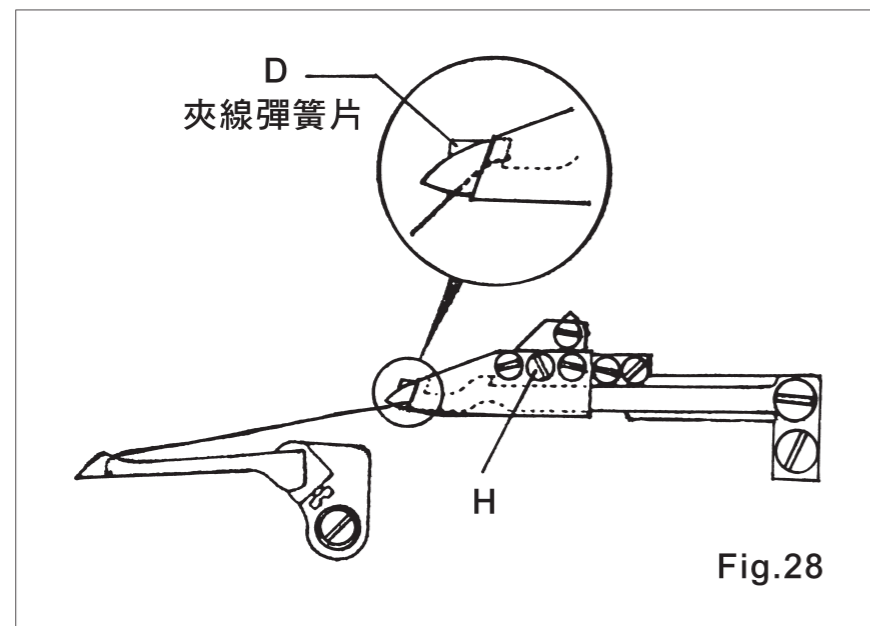

Fig.28



SHING RAY®

B 下切刀組、切線之相關位置：

1. 下切刀組之前後位置—

當下切刀組由右定點移出至下勾針右側時(第一段動作)活動片之刀尖(A)，約位於下勾針寬度中心，前後1/2位置。(圖29)

調整時可放鬆搖臂之偏心輪(B)上之螺絲(C)，再轉動偏心輪，使活動刀片移到正確位置。

偏心輪上之記號(D)正常時，大約處於3點鐘方向位置。(圖30)

注：

當要調整偏心輪(B)改變切刀角度位置時，必須先放鬆下切刀托架導引片(E)上之螺絲(F)，等調整好切刀組角度後再將導引片(E)輕輕靠在下切刀托架，鎖緊螺(F)。(圖30)

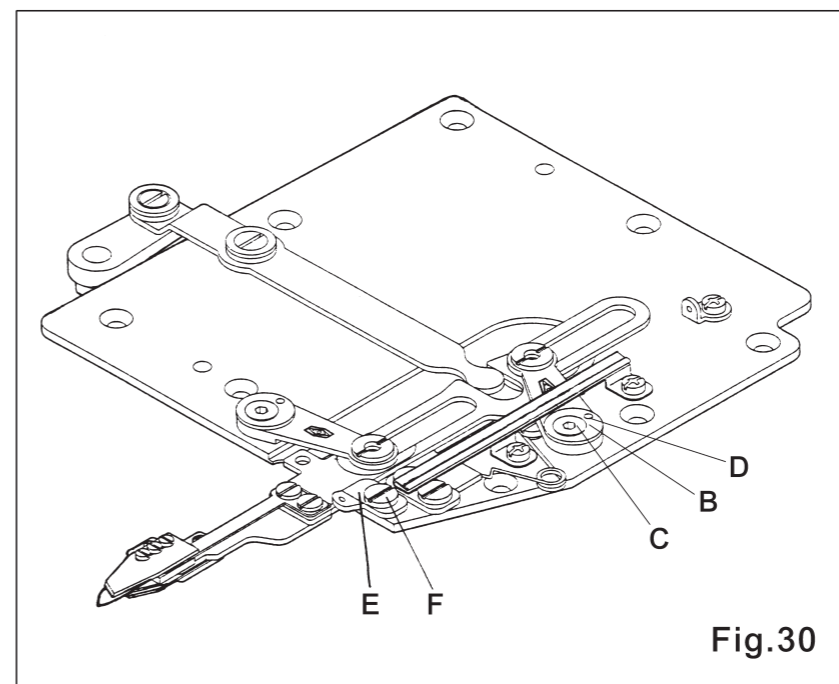

Fig.30

B. THE RELATIVE POSITION ADJUSTMENT OF BOTTOM TRIMMER.

1. The Front and Rear position of Bottom Trimmer—

When the trimmer moves out from right dead point to the right hand side of looper, (1st action) the tip of Moving Knife (A) aim to the center of looper ridge. (Fig. 29)

Please loose the screw (C) of Knife Guide Lever Eccentric Ring (B) and turn the Eccentric Ring for regulating the Moving Knife into right position.

Please set up the mark (D) of Eccentric Ring to 3 o'clock position in ordinary. (Fig.30)

Remark :

When you would like to adjust the Eccentric Ring for changing the angle of under trimmer, please loose the screw (F) of Lower Knife Carrier Guide. (E) Please let the Lower Knife Carrier Guide (E) touch Lower Knife Carrier in gently and lock the screw (F) down after the angle of trimmer have been adjusted. (Fig. 30)

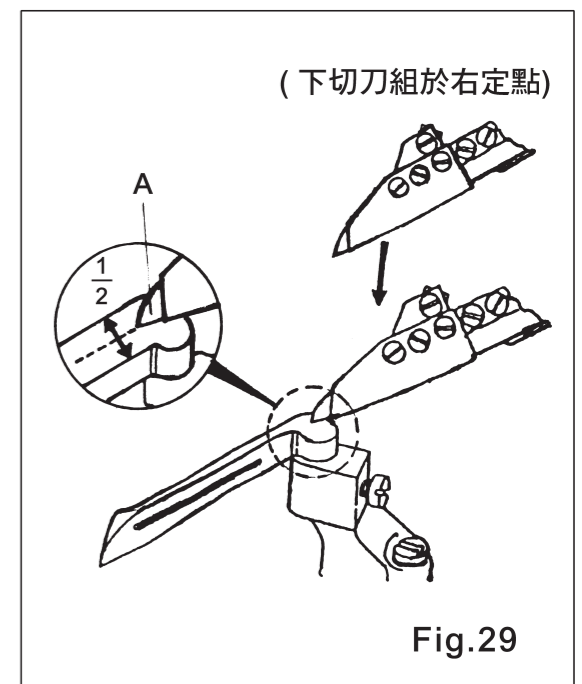
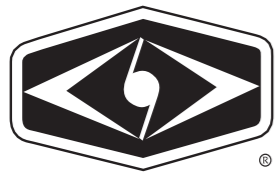

Fig.29



SHING RAY®

2. 下切刀組之左右位置—

當下切刀組之活動刀片(A)往左移至左定點時，活動刀(A)之刀尖，須超出下勾針(B)之左邊穿線孔約1mm。(圖31)調整時，可放鬆連結滑塊(C)上的螺絲(D)，再用螺絲刀旋轉螺絲(E)，微調活動刀片左右位置至正確點後，再鎖緊螺絲(D)。(圖32)

注意：

1. 下切刀組完成調整時，須再次用手動移出活動刀片，確認相關位置是否正確、順暢。
2. 當必須調整下切刀組相關位置時，須確認針棒是否處於上定點，下勾針位於左定點(此為切線點)。

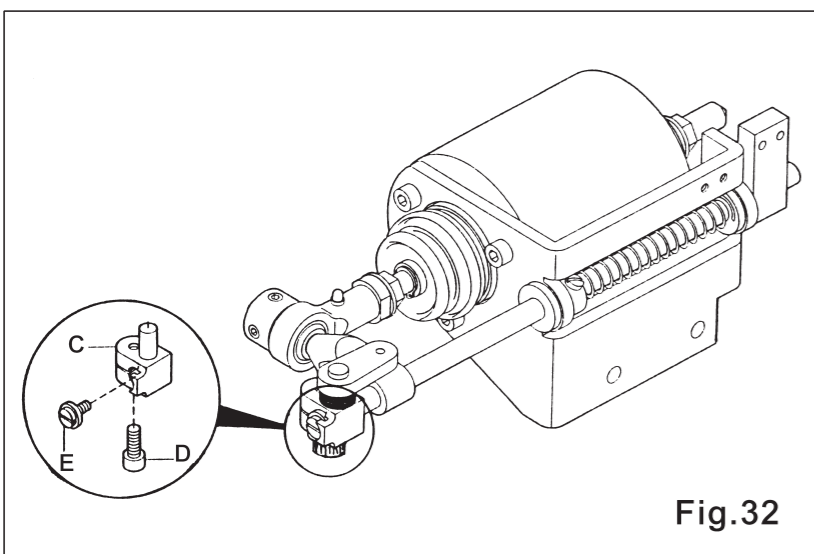

Fig.32

2. The Right and left position of Bottom Trimmer—

When the Moving Knife move to the left dead point, the tip of Moving Knife has passed 1mm over than the threading hole of looper. (Fig. 31) When you would like to adjust the right & left position of Moving Knife. First, please loose the screw (D) of Connecting Block (C), to turn the screw (E) by screwdriver for micro adjusting the correct right & left position of Moving Knife., then to locked the screw (D) down. (Fig.32)

Remark :

- (1)When you finish adjusted, please be moved the Bottom Trimmer by hand to confirm the relative position correctly & smoothly.
- (2)When you adjust the relative position of Bottom Trimmer, please always confirm the needle bar in the top dead point & the looper in the left dead point which are the timing of cutting thread.

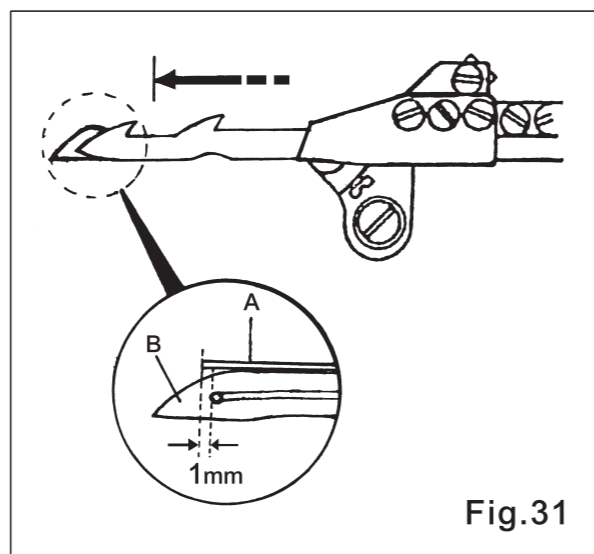

Fig.31



SHING RAY®

C 下切刀組與針線及下勾針線之關係：

1. 當活動刀片(A)往左邊移時，必須通過針線之線環(B)。(圖33-1)
2. 當活動刀片往左移至左定點時，下勾針線(C)須滑入活動刀片(A)之左邊刀口(D)內。(圖33-2)
3. 活動刀片往右回移時，活動刀片右刀口須勾住針線，左刀口勾住下勾針線，一起往右拉回。(圖33-3)
4. 針線及下勾針線由活動刀片拉回與固定刀切斷，針線切斷後自然脫落，下勾針線靠下勾針一端線頭須穩穩夾住於切刀。(圖33-4)

C. THE RELATIVE POSITION OF NEEDLE, LOOPER THREAD AND BOTTOM TRIMMER.

1. When the Moving Knife (A) move to the left which must be passed the loop (B) of needle thread. (Fig 33-1)
2. When the Moving Knife move to the left dead point which looper thread must be dropped into the left hook (D) of Moving Knife (A). (Fig.33-2)
3. When the Moving Knife move to the right, the right hook of Moving Knife must hooks the needle thread and left hook must hooks the looper thread to pull into right side in same time. (Fig.33-3)
4. The needle & looper thread are pulled back by Moving Knife and be cut by Fixing Knife. The needle thread must be cut in efficiently and looper thread has clipped by Bottom Trimmer in stably. (Fig.33-4)

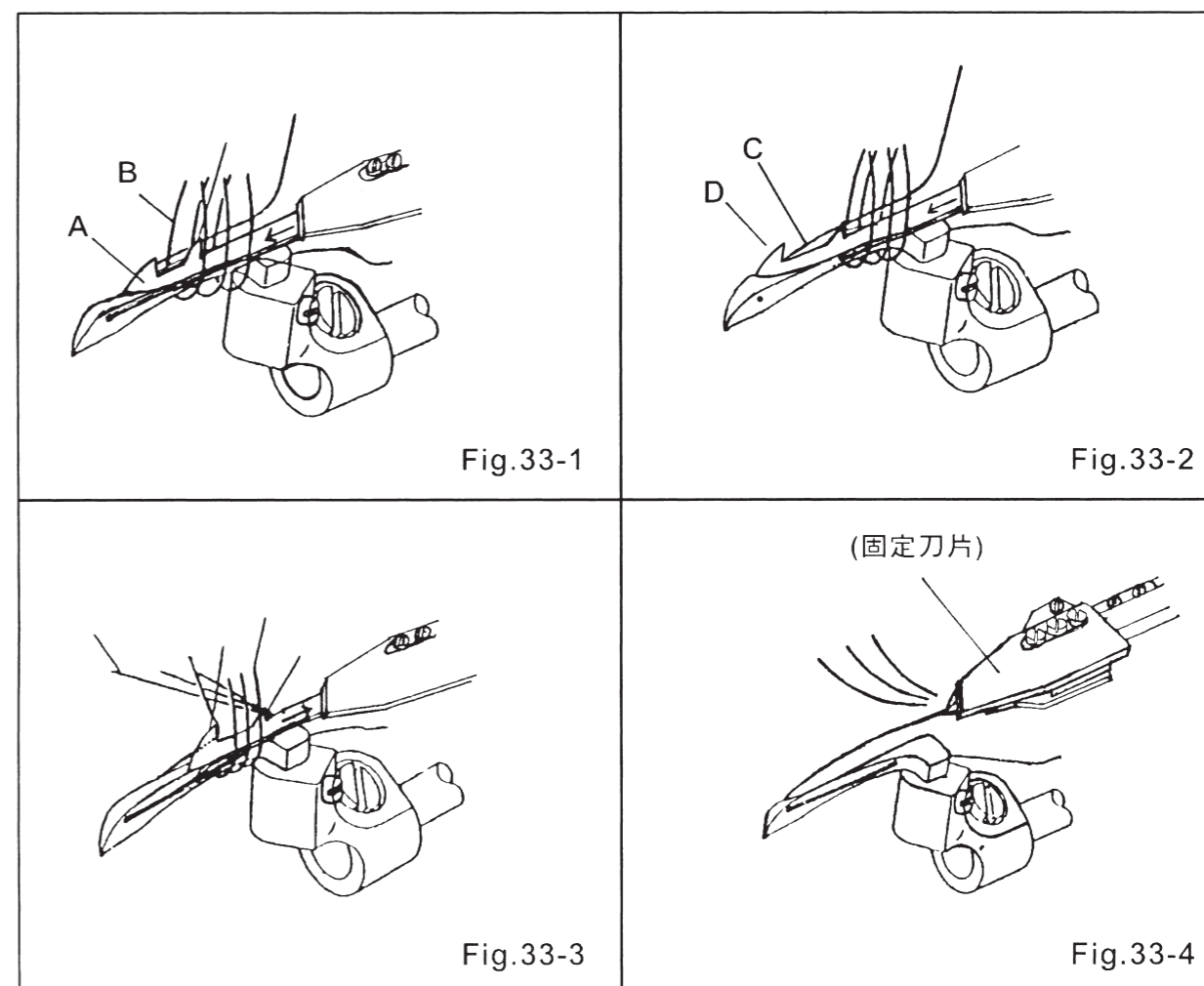

Fig.33-1

Fig.33-2

Fig.33-3

Fig.33-4



SHING RAY®

D 上切刀組與上飾線、針及勾針之關係：

注：

安裝調整上切刀組前，必須先確認針棒是否停於上定點，且上勾針之相關位置必須處於正常狀態下。

1. 下切刀組高度調整：

當活動刀片(A)移至最低點時活動刀之刀尖與上勾針(B)之上沿須切齊等高(C)。(圖34)調整時放鬆上切刀組(D)上之兩個螺絲(E)，再上下移動上切刀組之位置。(圖25)

2. 上切刀組之刀片壓力調整：

上切刀組之活動刀與固定刀壓力可由螺絲(F)旋轉微調至適當壓力。(圖35)

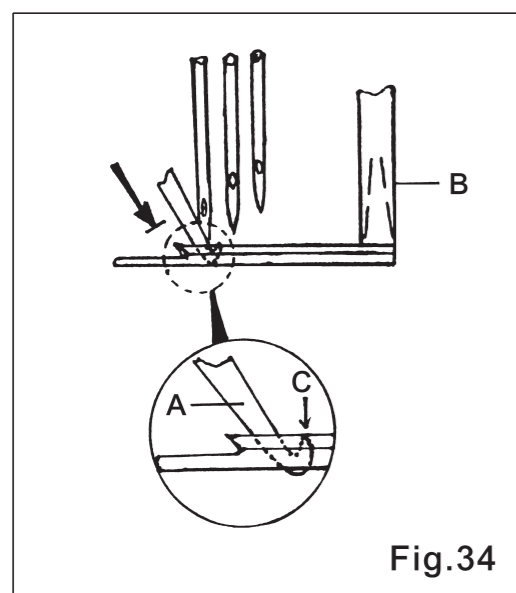

Fig.34

D. THE RELATIVE POSITION OF SPREADER THREAD, NEEDLE, SPREADER AND TOP TRIMMER.

1. The height adjustment of Top Trimmer—

When the Top Trimmer Moving Knife move to the lowest point, the tip (C) of Moving Knife align with top of Spreader (B). (Fig.34)

To loose the two screws (E) of Top Trimmer (D) then, to adjust up and down for top trimmer position. (Fig.35)

2. The pressure adjustment of Top Trimmer—

The pressure of Top Trimmer Moving & Fixing Knife which be adjusted via micro turn the screw (F) to get the suitable pressure. (Fig.35)

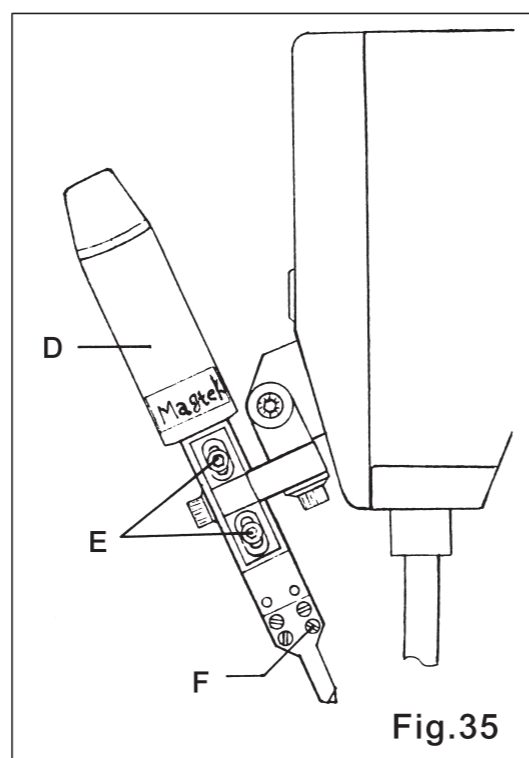

Fig.35



SHING RAY®

3. 上切刀組角度之調整：

注：

調整上切刀組角度前，須先調好上切刀組之高度。

當活動刀片(A)往下移至下定點時，活動刀片(A)須位於針及上勾針(B)之間隙中央，特別注意不可和針磨擦碰撞(圖36)。且活動刀片(A)往下移時，刀片前端斜面須和上飾線有磨擦接觸情形(C)(圖37)，當活動刀片往上收刀時，上飾線才能順利滑入刀槽內。

調整上述關係位置時，可放鬆上切刀組(D)之固定座上螺絲(E)、(F)、(G)調整。(圖38)

三個螺絲放鬆順序為(E)→(F)→(G)；鎖緊時則反向順序為(G)→(F)→(E)。

3. The angle adjustment of Top Trimmer—

Remark :

Before to adjust the angle of Top Trimmer, please make sure the height of Top Trimmer is correctly.

When the Top Trimmer Moving Knife (A) move to the lowest point, the Moving Knife (A) must be located in the center of needle and spreader (B). We would like to special mention that the Moving Knife don't touch and collide the needle. (Fig.36) When the Moving Knife moves down, the top bevel of Moving Knife must be touch the spreader thread (C) (Fig.37) which will cause the spreader thread drop into the hook of Top Trimmer Moving Knife.

To adjust the above relative position, please loose three screws (E), (F), (G) of Top Trimmer Fixed Block for adjusting. (Fig.38)

To loose the three screws step is (E)-(F)-(G) and lock down step is (G)-(F)-(E).

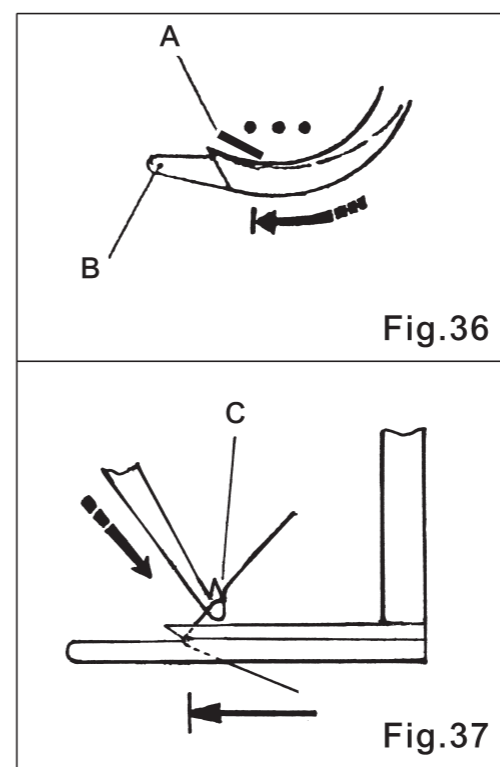

Fig.36

Fig.37

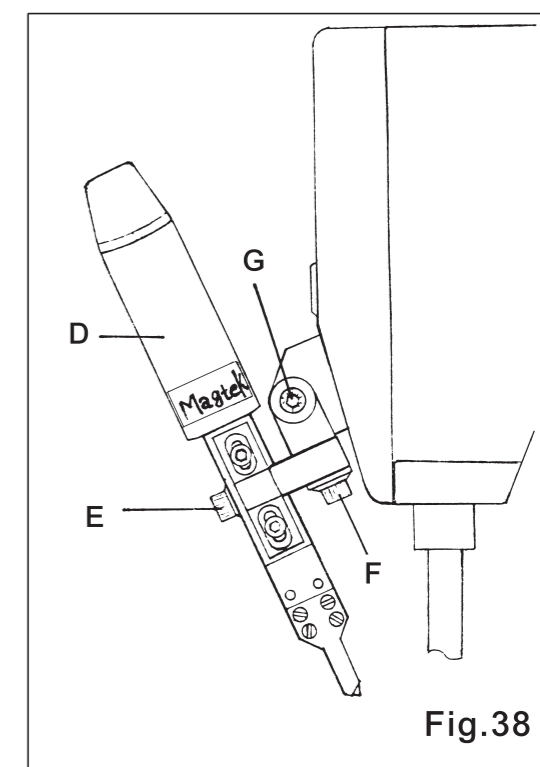

Fig.38



SHING RAY®

E 撥線器相關位置調整：

1. 撥線器(A)之高度—

當撥線片(B)往下擺動至呈水平狀態時，撥線片底部與左針之針尖正好切齊，此為撥線器之高度。(圖39)

2. 撥線片(B)之前後位置—

當撥線片(B)通過押腳時，撥線片與押腳前沿之間隙為1mm。(圖39)

3. 撥線片(B)之左右位置—

當撥線片(B)移到左定點時，撥線片之勾線尖端與左針之距離約為3.5mm。(圖40)

注：

調整時，可放鬆兩個螺絲(C)，調整撥線器(A)之相關位置。(圖41)

E. THE RELATIVE POSITION OF TOP WIPER.

1. The height of Top Wiper (A)—

When the Wiper (B) swings to the bottom in level, the bottom of Wiper align with the tip of left needle which is the height of Top Wiper. (Fig.39)

2. The front & rear position of Wiper (B)—

When the Wiper (B) passed the Presser Foot, the clearance between the Wiper and Presser Foot is 1mm. (Fig.39)

3. The right & left position of Wiper (B)—

When the Wiper (B) swings to the left dead point, the clearance between the hook tip of Wiper and left needle is 3.5mm. (Fig.40)

Remarks :

To loose the two screws (C) for adjusting the relative position of Top Wiper (A). (Fig.41)

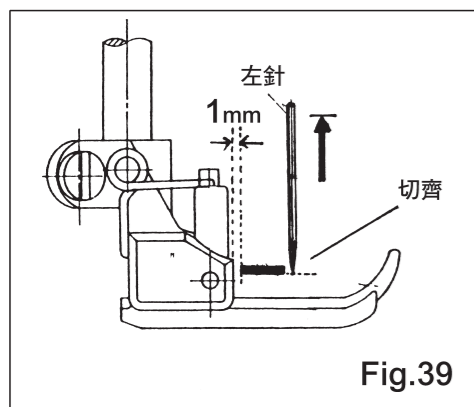

Fig.39

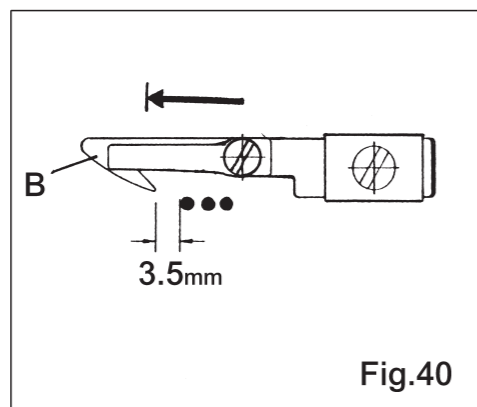

Fig.40

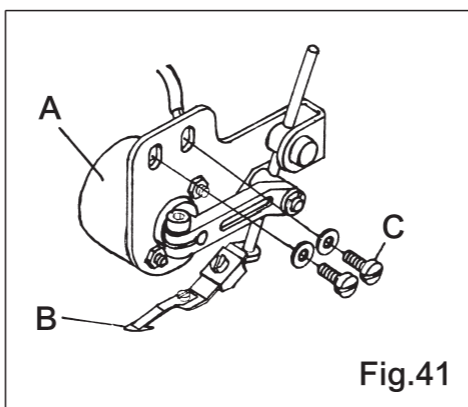

Fig.41



SHING RAY®

簡易故障排除

REGULAR MAINTENANCE :

A 清潔保養：

1. 機器外表須經常保持乾淨避免棉屑阻塞過線孔及夾線片，造成線跡不順。
2. 針板下方之送布牙架結構(A)縫隙之清潔最為重要，須經常清除乾淨。如有積油而造成滲油情況，就是棉屑累積太多或吸油管阻塞造成的。故須定期清除送布牙架(A)裡面及更換回油管之吸油海棉(B)、(C)。(圖42)

A. THE CLEAR AND MAINTENANCE.

1. Please always clean the machine appearance to avoid the cotton waste obstructs the threading hole and thread clamp which to cause the stitch unstable.
2. It's very import to always clean the crack (A) of feed dog system which under the needle plate. If the cotton waste accumulate too many in cylinder or block the suck oil tube for which will cause the oil leaking. Please always clean the Feed-Dog System and change the felt of suck oil tube (B), (C) in regularly. (Fig.42)

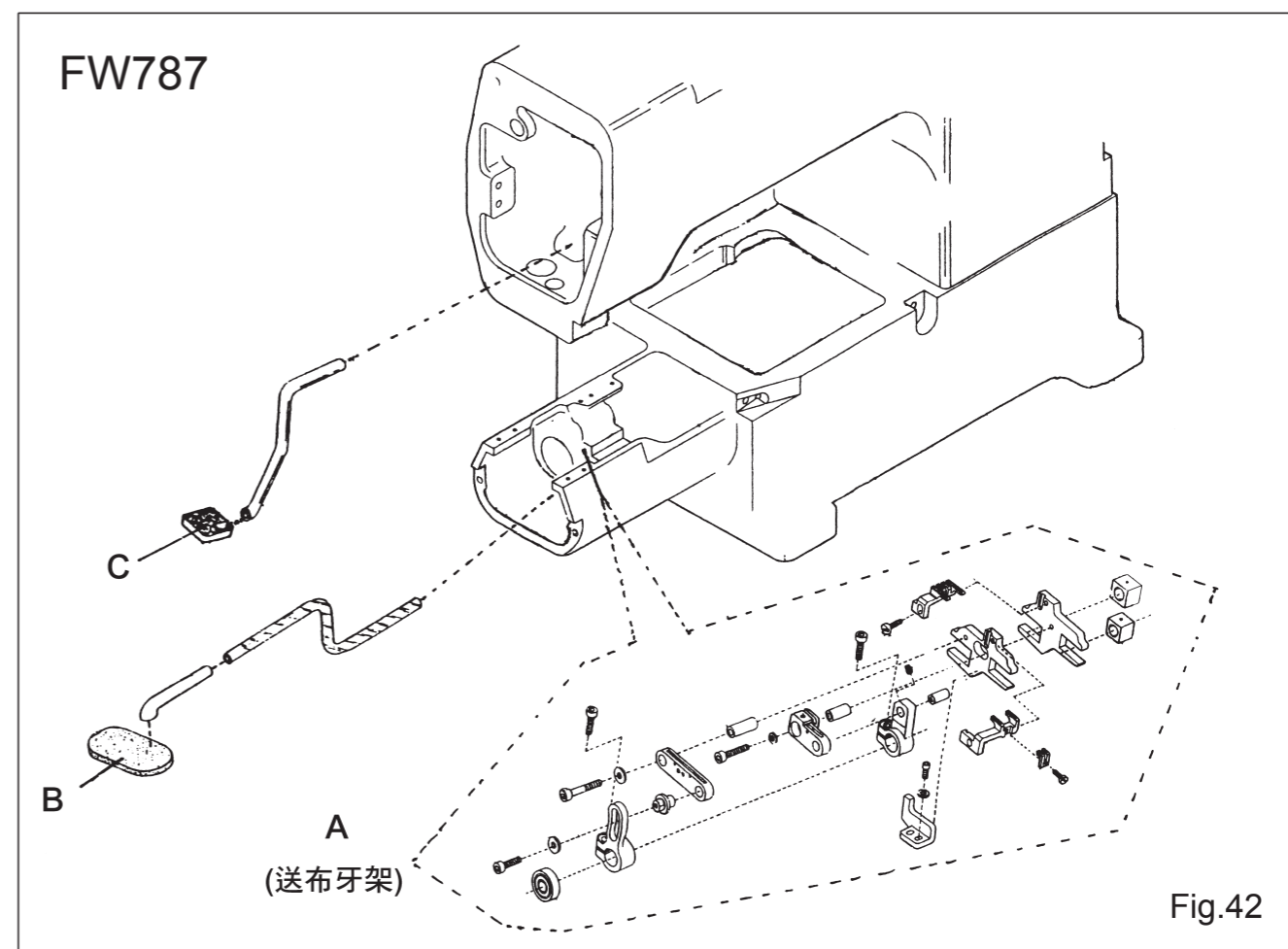
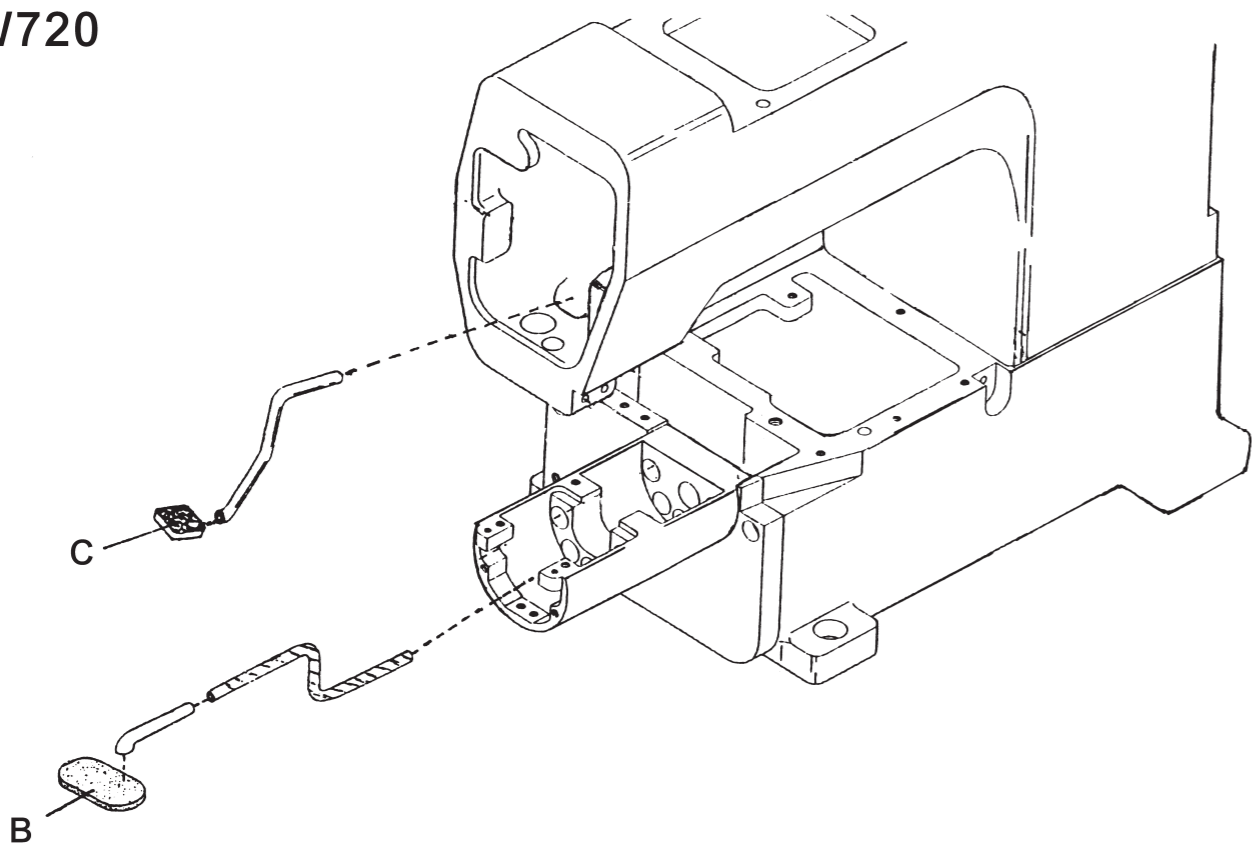

Fig.42



SHING RAY®

FW720



(送布牙架結構圖)

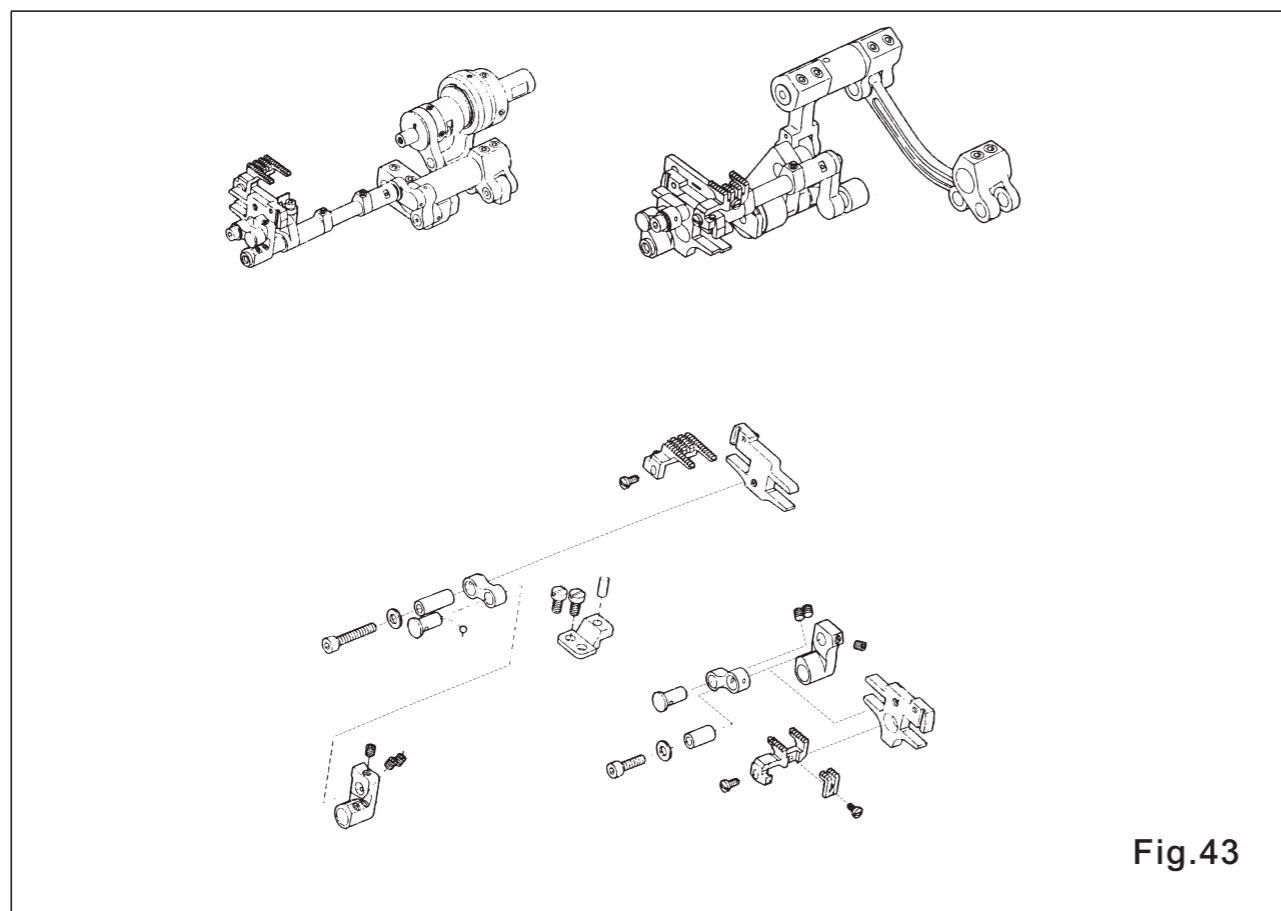

Fig.43



SHING RAY®

B 故障(用戶)自主檢查：

狀況1：跳針、斷線—

排除：

- A 是否使用錯誤型號之機針。
- B 使用機針是否已彎曲，毛邊或未裝至定位或未裝正。
- C 車縫線是否存放過久或線本身粗細不均，接頭太多或有漏穿線情形。
- D 注意針線及底線(下勾針線)之控線沙拉組是否太緊或太鬆。
- E 底線(下勾針線)之控線凸輪時位關係，檢查是否已走位。(此項須由技術人員檢查調整)
- F 檢查前後護針片之相關位置是否正確。(此項須由技術人員檢查調整)
- G 下勾針尖是否已毛邊磨損，或下勾針與針之時位關係已被調整走位。(此項須由技術人員檢查調整)

狀況2：車縫不順產生布料波浪或斜紋狀況—

排除：

- A 針對布料性質調整前牙差動比率：
波浪情形—前牙差動調大；
斜紋情形—前牙差動調小。
- B 注意押腳壓力須適中，且不能與針板面有間隙。

B. ERROR MESSAGES (THE USER INSPECTS THE MACHINE BY THEMSELVES)

Status 1: Skipped Stitch, Broken Thread-
Solution :

- (a) Do you use a wrong model needle?
- (b) Does the needle bent? Does the tip of needle cracked? Or, the needle doesn't be installed in correctly position.
- (c) Does the thread keep in stock too long? Does the thread's thickness uneven? Does the thread too many connectors? Or, there is lose threading some threading eyelet.
- (d) Please check the tension of needle & looper thread have been adjusted too loosen or too tight by Thread Tension Adjuster.
- (e) The looper thread take-up is out of timing. (Please ask the machinist to check and adjust it.)
- (f) Please check the relative position of Front & Rear Needle Guard are correctly. (Please ask the machinist to check and adjust it.)
- (g) Please check the tip of looper have cracked or wore. The timing of looper and needle is out of order. (Please ask the machinist to check and adjust it.)

Status 2: The Unstable Sewing engender Puckering and the folding parts didn't be seamed in even -

Solution :

- (a) To refer the nature of fabric for adjusting the differential feed-dog. Differential Rate :
Puckering — To adjust the differential feed-dog ratio in large.
The folding parts didn't be seamed in even-To adjust the differential feed-dog ratio in small.
- (b) The pressure of presser foot must be moderately. Please take care that the needle plate between presser foot didn't have any gap.

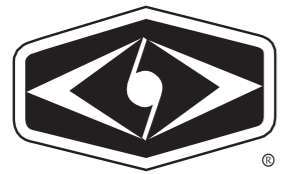

SHING RAY®

- C 送布牙須視車縫布料之厚薄、伸縮性質，調整適當高度。
- D 車縫人員控制衣物之手勢、力道，須視布料性質不同做配合。

狀況3：機器產生異音情形—

排除：

- A 檢查機頭與桌板之固定螺絲、墊片、防振塑膠等之安裝方式是否未依安裝說明安裝，而產生桌板共振之異音。(以直驅式小馬達機器為主)
- B 檢查機器前蓋、面蓋螺絲是否有鬆脫或有因拆裝後未密合即再鎖緊，而產生的異音。
- C 檢查油量是否太少，造成機器潤滑不夠、發燙產生之異音。

狀況4：不噴油或不吸油情形—

排除：

- A 檢查噴油管及吸油管是否有破裂或接頭未鎖緊而有漏氣情形。
- B 送布牙架下方之吸油管及針棒內側之吸油管、如有積油情形時須檢查是否因棉屑累積太多未清除造成吸油管阻塞。

- (c) The height of feed-dog must be refer to the nature of fabric for adjusting a reasonable height.
- (d) The operator is according to the nature of fabric for adjusting the holding way of sewing and the tension of fabric be seamed.

Status 3 : The machine noise in operation-
Solution :

- (a) Please always follow the installation to fix the machine head and table. The wrong installation will engender the noise which come from the machine head and table resonance.
(Main item : D.D. Type Mini ServoMotor)
- (b) Please check the front cover and screws. If the noise come from the loosen screw or front cover, please screw and fix them again.
- (c) Please check the lubrication oil is enough or not? If the lubrication oil isn't enough which will to cause the machine noise and heat.

Status 4 : The lubrication system don't spout out the oil or inhale the oil back-

Solution :

- (a) Please check the oil tube have broken or not? Does the connector be locked well? If the oil tube had broken, please change it. If the connector didn't lock well, please lock it well.
- (b) If there are a lot of oil in the bottom of cylinder-bed or the bottom of needle bar, please check these two places have accumulated a lot of cotton waste to block the Inhale Oil Tube or not?
"Please always clear the cotton waste at least two times per week."



SHING RAY®

- C 檢查吸油管與吸油海棉是否正常接觸。

狀況5：機器產生異音情形—

排除：

- A 切線點不對，機器停的時候針棒是否未停在上死點。
- B 下切刀之活動刀片，前進至左定點時，行程是否不夠。
- C 下切刀組向左前方移出時(第一段動作)刀尖之前後位置是否不正確。
- D 刀片彈簧壓力是否調得太弱。
- E 檢查活動刀，固定刀是否有磨損或相關位置有異位。
- F 電壓過低造成傳動之電磁閥力道變弱。
- G 針板下方棉屑是否積存太多而影響活動刀無法準確進入線圈。

狀況6：上飾線(網線)切大斷情形—

排除：

- A 依照上切刀之調整說明，檢查活動刀片剪線之相關位置是否正確。
- B 檢查上切刀上之彈簧壓力是否太弱。
- C 檢查上勾針之相關位置及行程是否正確。

- (c) Please check the Inhale Oil Tube have connect with Inhale Felt in correctly place.

Status 5 : The "Bottom Trimmer" can't cut the needle & looper thread out -

Solution :

- (a) The point of trimming is incorrect. The needle bar didn't stop at top dead point when the machine stop.
- (b) The moving knife of bottom trimmer move to the left dead point which the moving stroke isn't enough.
- (c) In 1st motion of Bottom Thread Trimmer, the tip of moving knife which position is correctly or not?
- (d) Is the pressure of clamp spring too weak?
- (e) Please check the moving & fixing knife have abraded or relative position is out of order.
- (f) As the voltage drop, to cause the power of solenoid for trimmer is going to weak.
- (g) There is too much cotton waste to accumulate under the needle plate which impede the moving knife didn't enter the thread hole inprecisely.

Status 6 : The "Top Trimmer" can't cut the spreader thread out-

Solution :

- (a) Please follow the installation manual of top trimmer to check all of top trimmer relative position is correctly or not?
- (b) Please check the pressure of top trimmer clamp spring is too weak or not?
- (c) Please check the relative position & stroke of spreader is correctly or not?

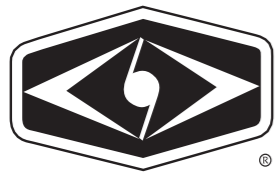

SHING RAY®

狀況7：撥線器無法將針線頭撥起時—
排除：

- A 先試縫確認每次切線時，針線是否每次都有被下切刀完全切斷；因針線未被下切刀切斷時，撥線器則無法順利將線頭撥離針板面。
- B 檢查撥線器，安裝之位置是否有依前述說明正確安裝。
- C 檢查撥線器，回歸時彈力是否異常太弱，有活動不良的情形。

註：

如是針線未被切斷導致撥線器無法將線頭拉出而卡在針下方時，必須先用剪刀剪斷針線，使撥線器之撥線勾針能回歸原點，否則會造成針與撥線勾針相互碰撞的情形。

狀況8：前踩踏板、機器不能運轉時—
排除：

- A 檢查保護下切刀組回歸定位之安全開關小綠燈是否亮著(位於機頭後方，安全開關上)。如未亮則表示下切刀組未回歸定位，安全開關自動斷電以保護下切刀不被碰撞。
- B 檢查電腦控制箱顯示之代號，再對照馬達說明書之故障代號說明，排除問題。

Status 7 : The thread wiper can't take the needle thread up -

Solution :

- (a) Please double confirm the bottom trimmer have always cut the needle thread. If the needle thread didn't be cut out, the wiper is impossible to take the needle thread up. (*)
- (b) Please check the position of thread wiper have followed the installation manual to set up in correctly.
- (c) Please check the return elasticity of top wiper is too weak, or the wiper didn't move smoothly.

Remark :

If the needle thread didn't be cut by trimmer which will cause the "Top Wiper" can't take the needle thread up. Please use the thread clipper to cut the needle thread which didn't be cut by under trimmer. To let the "Top Wiper" return back to the initial place which to avoid the hook of wiper crash the needle.

Status 8 : To step on the pedal in the front which the machine didn't operate -

Solution :

- (a) Please check the green light on the Under Trimmer Position Security Switch is be switched on or off. (The green light locate at back side of machine head) If the green light is be switch off which meaning is that under thread trimmer didn't return back the position, the Security Switch have broken the electric power in automatic which to avoid the Loooper crash the under thread trimmer.
- (b) Please check the error code which be showed on the screen of control box. then, to follow instruction manual for solving the problem.



SHING RAY®

C 檢查機頭馬達與電腦控制箱之中繼線、插頭是否有鬆脫或未插緊，而造成接觸不良的情形。

狀況9：後踩踏板時，切刀組及自動抬押腳全無動作之情形—

排除：

- A 檢查機頭後方之連接端子上電線是否脫落，造成各活動部位(下切刀、上切刀、抬押腳)未接收到訊號，而無法動作。
- B 用手動方式檢查切刀機構及鬆線機構是否順暢無卡死情形。
- C 檢查電腦控制箱上顯示之代號，對照說明書上顯示之代號，對照說明書上之異常狀況為何。

C 敬愛的用戶們:

這本「操作說明書」希望能使您更了解星銳公司的產品，也能助您排除一些異常狀況；如有任何無法解決或維修上的問題，非常歡迎您與我們各地區之經銷、代理商連絡，他們都非常樂意為您服務，謝謝大家的愛護與支持。

(c) Please check the plug of junction line which between the servo motor and control box. Have the plug been plugged in well? Or, the plug has plugged too loose which to cause the bad connection.

Status 9 : To step on the pedal in rear which the Thread Trimmer System and Pressure Foot Lifter didn't operate -

Solution :

- (a) Please check the terminal of Top, Bottom Thread Trimmer and Pressure Foot Lifter junction line for which locate at backside of machine head. If the terminal didn't connect well, the signal is going to bad transmission to cause these moving parts didn't operate.
- (b) Please use your hand to push the Under Thread Trimmer System and Thread Pull-Off Mechanism. Then, Please check these mechanisms move smoothly or not?
- (c) Please check the error code which be showed on the screen of control box. then, to follow instruction manual for solving the problem.

C. CONCLUSION :

Dear Users,
We hope this "Instruction & Maintenance Book" could offer you more information about our "Shing Ray" products and help you to solve these unusual conditions of our machine.
If you have any further requested and some problems about the maintenance, we are warmly welcome you to contact with our distributor and sloe agency in your country. All of them are willing to service you. Finally, we are sincerely to thanks all of yours continuing supports.